

1 Features

1.1 Hardware

- High-performance, low-noise MEMS IMU
- Supports a wide input voltage range up to 36 V
- IP67-rated waterproof protection
- Multiple interface options are available, including USB, UART (TTL / RS-232), and RS-232 + CAN
- Supports pulse triggering and PPS + GPRMC time synchronization
- Multi-function I/O for synchronization, alarm signaling, and user-defined functions
- Integrated temperature sensor
- Factory-calibrated and temperature-compensated over the full temperature range from -40 °C to 85 °C, including bias, scale factor, and cross-axis compensation
- The product design complies with applicable RoHS requirements. For information on other compliance documentation and certification status, refer to the latest official documentation.
- Customization options are available



1.2 Software

- Adaptive EKF sensor fusion algorithm
- Supports output rates up to 1000 Hz, depending on configuration, with low output latency.
- Fusion algorithm optimized for dynamic attitude tracking and vibration suppression
- Under typical dynamic operating conditions, the fusion algorithm reduces the effect of linear acceleration on attitude estimation
- Supports serial binary and CAN communication protocols
- Comprehensive command set for user configuration
- GUI software for convenient configuration and debugging
- Reference examples are available for ROS 1, ROS 2, C, MATLAB, Python, Arduino, and other platforms

1.3 Key Specifications Summary

Table 1: Key Specifications Summary

Item	HI18M0	HI18S2	HI18S3
Function	IMU/VRU	IMU/VRU	IMU/VRU/AHRS
Magnetometer	×	×	√
Features	Entry-level solution for basic attitude sensing	High-performance, low-noise solution for high-resolution applications	High-performance, low-noise solution for high-resolution applications
Interface	Entire series: USB, UART (TTL / RS-232), and RS-232 + CAN		
Dimensions	All M8 connector models: 40 × 27 × 14 mm (including connector length); housing size: 28 × 27 × 14 mm		

2 Applications

The HI18 series is designed for high-performance attitude sensing in demanding operating conditions and is suitable for attitude measurement and control in environments involving temperature variation, vibration, and dynamic motion. Typical applications include:

- service robots
- humanoid robots
- low-speed autonomous mobile robots
- smart agricultural machinery

3 Description

3.1 System Block Diagram

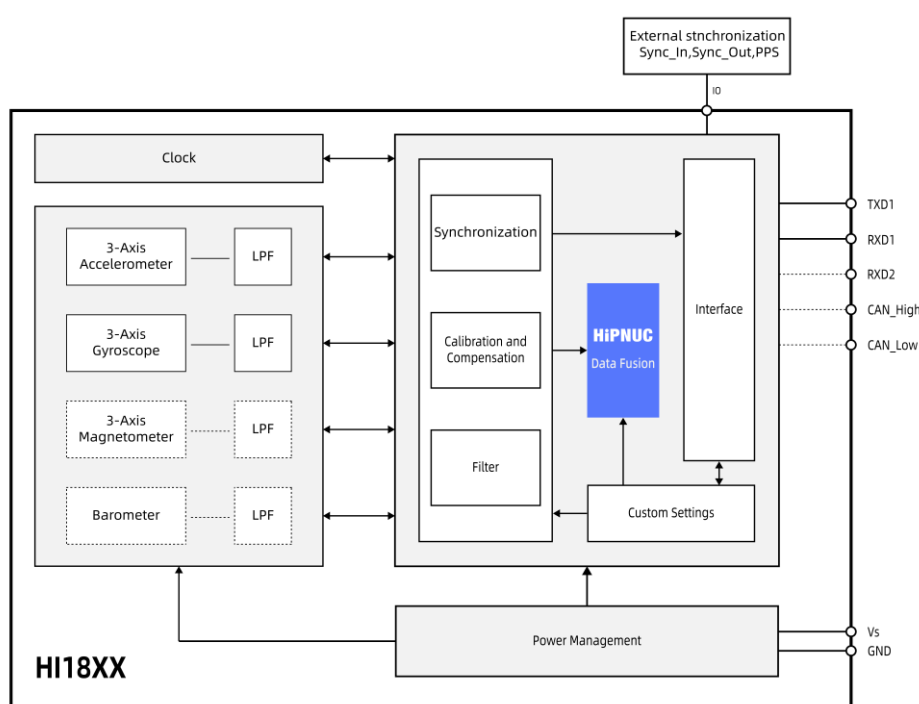

Figure 1: HI18 Series System Block Diagram

Note 1: Dashed lines indicate functions not supported by certain models; refer to Table 1 for details.

3.2 General Description

The HI18 series is a MEMS-based IMU/VRU/AHRS sensor module with proprietary adaptive extended Kalman filtering and motion analysis algorithms. It outputs raw acceleration and angular rate data and, on supported models, magnetic field data. It also provides attitude outputs such as Euler angles and quaternions. Depending on the model, the HI18 series supports IMU, VRU, or AHRS functions. Refer to Table 1 and Table 2 for model-specific features.

Each module is factory-calibrated for bias, scale factor, and cross-axis compensation, and is temperature-compensated over the specified operating range.

The HI18 series supports UART (TTL / RS-232), CAN, and USB communication. The GUI software supports parameter configuration, data visualization, firmware upgrade, and data logging. Refer to the ordering code for the exact model configuration.

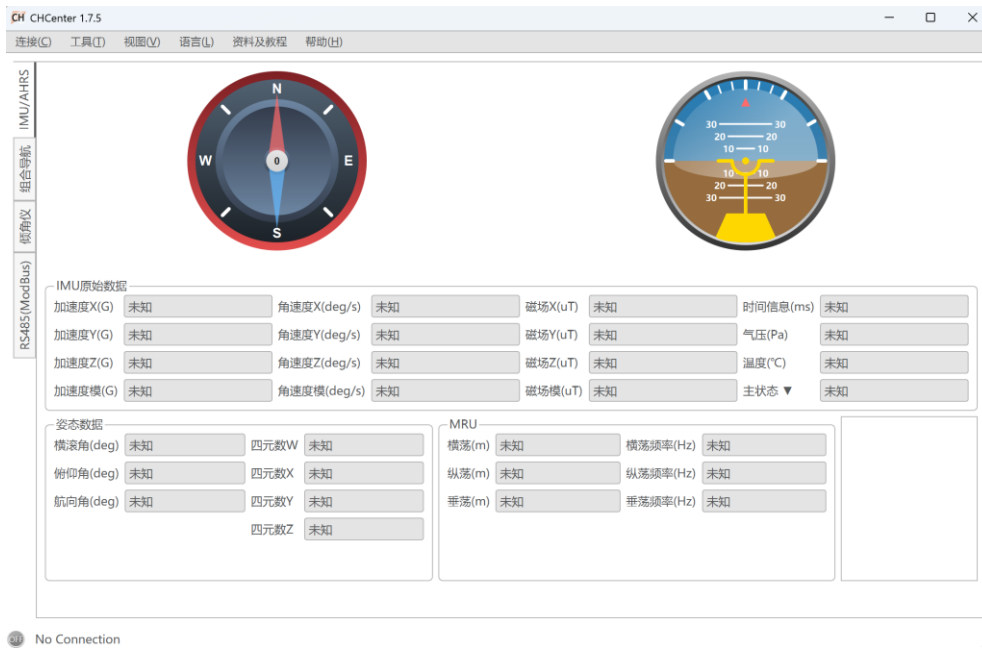

Figure 2: GUI Software

Contents

1 Features	1
1.1 Hardware	1
1.2 Software	1
1.3 Key Specifications Summary	1
2 Applications	2
3 Description	2
3.1 System Block Diagram	2
3.2 General Description	2
4 Product Selection	6
5 Ordering Information	7
5.1 HI18 M8 Connector Ordering Codes	7
5.2 Contact Information	7
6 Document Information	8
6.1 Revision History	8
6.2 Related Documents	8
7 HI18 System Architecture	9
7.1 IMU	9
7.2 VRU	9
7.3 AHRS	9
8 Interface and Pin Definitions.....	10
8.1 M8 8-Pin UART (TTL) Pin Definitions.....	10
8.2 M8 8-Pin UART (RS-232) Pin Definitions	10
8.3 M8 8-Pin MI1 (RS-232 + CAN) Pin Definitions	11
9 Specifications.....	12
9.1 Gyroscope	12
9.2 Accelerometer	14
9.3 Magnetometer	15
9.4 Temperature Sensor Specifications.....	15
9.5 Fusion Accuracy	15
9.6 Typical Usage Limits.....	15
10 System and Electrical Parameters	16
10.1 Electrical Parameters	16
10.2 Interface Parameters	16
10.3 System Parameters.....	16
10.4 Absolute Maximum Ratings.....	17
11 Mechanical Dimensions.....	18

11.1 HI18 M8 Mechanical Dimensions 18

11.2 IMU Center Location 18

12 Coordinate System 19

12.1 ENU (Default)..... 19

12.2 NWU and NED 19

13 Installation 20

14 Cable 21

14.1 USB Type-A to M8 A-Coded Female Connector Cable (RS-232) 21

14.2 USB Type-A to M8 A-Coded Female Connector Cable (TTL) 21

14.3 DB9 Female Connector + Flying Leads to M8 8-Pin A-Coded Female Connector Cable..... 21

14.4 Flying Leads to M8 8-Pin A-Coded Female Connector Cable 21

14.5 Applicable Products for Cables..... 22

14.6 Default Factory-Supplied Cable 22

15 How to Connect 23

15.1 UART (TTL / RS-232) 23

15.1.1 UART (TTL / RS-232) to USB 23

15.1.2 UART (RS-232), DB9 Connector (Trigger Synchronization) 23

15.1.3 UART (RS-232), DB9 Connector (PPS + GPRMC Synchronization)..... 23

15.1.4 UART (TTL / RS-232), Flying Leads (Trigger Synchronization)..... 24

15.1.5 UART (TTL / RS-232), Flying Leads (PPS + GPRMC Synchronization)..... 24

15.2 MI1 (RS-232 + CAN) 24

15.2.1 MI1 Interface, DB9 + Flying Leads Cable 24

15.2.2 MI1 Interface, Flying Leads Cable..... 25

16 Default Configuration 26

17 Communication Protocols..... 27

17.1 Serial Binary Protocol..... 27

17.2 CAN 27

18 Disclaimer 28

4 Product Selection

Table 2: Selection Information

Coding format: HI18-a-b-c-d-e						
Identifier	Series	a-Sensor	b-Interface	c-Synchronization	d-Connector	e-Other Information
HI	18	M0: IMU/VRU	USB (RS-232): USB-to-UART (RS-232)	0: No 1: Yes	0: M8	0: Default Others: Custom
		S2: IMU/VRU	USB (TTL): USB-to-UART (TTL)			
		S3: IMU/VRU/AHRS	URT: UART (TTL)			
			232: UART (RS-232)			
			MI1: RS-232 + CAN			

Note 1: For current standard models, refer to the “Ordering Information” section. Other configurations are available as custom options.

Note 2: The synchronization functions supported by the HI18 series include pulse trigger and PPS + GPRMC.

Note 3: In the following sections, HI18XX refers to all products in the HI18 series. HI18SX refers to HI18S2 and HI18S3.

Note 4: Taking HI18S3-URT-100 as an example, the first digit “1” indicates synchronization support, the second digit “0” indicates an M8 connector, and the third digit “0” indicates the default configuration.

Table 3: HI18 Series Module Configuration

Model	3-Axis Accelerometer	3-Axis Gyroscope	3-Axis Magnetometer
HI18M0	√	√	×
HI18S2	√	√	×
HI18S3	√	√	√

5 Ordering Information

5.1 HI18 M8 Connector Ordering Codes

Table 4: HI18 M8 Connector Ordering Codes

Interface	Model	Name	Description
UART (TTL)	HI18M0-URT-100	IMU/VRU Module	Standard, Synchronization, TTL
	HI18S2-URT-100	IMU/VRU Module	High-performance, low-noise, Synchronization, TTL
	HI18S3-URT-100	IMU/VRU/AHRS Module	High-performance, low-noise, Synchronization, Magnetometer, TTL
UART (RS-232)	HI18M0-232-100	IMU/VRU Module	Standard, Synchronization, RS-232
	HI18S2-232-100	IMU/VRU Module	High-performance, low-noise, Synchronization, RS-232
	HI18S3-232-100	IMU/VRU/AHRS Module	High-performance, low-noise, Synchronization, Magnetometer, RS-232
USB (RS-232)	HI18M0-USB(RS-232)-000	IMU/VRU Module	Standard, USB-to-UART (RS-232)
	HI18S2-USB(RS-232)-000	IMU/VRU Module	High-performance, low-noise, USB-to-UART (RS-232)
	HI18S3-USB(RS-232)-000	IMU/VRU/AHRS Module	High-performance, low-noise, Magnetometer, USB-to-UART (RS-232)
USB (TTL)	HI18M0-USB(TTL)-000	IMU/VRU Module	Standard, USB-to-UART (TTL)
	HI18S2-USB(TTL)-000	IMU/VRU Module	High-performance, low-noise, USB-to-UART (TTL)
	HI18S3-USB(TTL)-000	IMU/VRU/AHRS Module	High-performance, low-noise, Magnetometer, USB-to-UART (TTL)
MI1 (RS-232 + CAN)	HI18M0-MI1-000	IMU/VRU Module	Standard, MI1 (RS-232 + CAN)
	HI18S2-MI1-000	IMU/VRU Module	High-performance, low-noise, MI1 (RS-232 + CAN)
	HI18S3-MI1-000	IMU/VRU/AHRS Module	High-performance, low-noise, Magnetometer, MI1 (RS-232 + CAN)

5.2 Contact Information

- Email: sales@hipnuc.com
- Website: www.hipnuc.com

6 Document Information

6.1 Revision History

Table 5: Revision History

Version	Date	Author	Change Description
1.0	Mar 21, 2024	Hipnuc	Initial release

6.2 Related Documents

1. Command and Programming Manual
2. STEP module
3. RoHS and other compliance documents
4. GUI software and reference examples

7 HI18 System Architecture

The HI18 series supports different output capabilities depending on the model, including IMU, VRU, and AHRS. It also supports multiple operating modes, such as 6-DoF mode, AHRS mode, and humanoid mode.

Depending on the model configuration, the HI18 module may integrate a 3-axis accelerometer, a 3-axis gyroscope, a 3-axis magnetometer, and a high-performance processor. The processor is mainly used for sensor synchronization, calibration, algorithm fusion, and user configuration. The humanoid mode is specifically optimized for the attitude characteristics of bipedal / humanoid robots. For details, refer to the Command and Programming Manual.

7.1 IMU

The IMU function outputs 3-axis acceleration and 3-axis angular rate data. On supported models, 3-axis magnetic field data is also available. These outputs support external processing and custom algorithm development.

7.2 VRU

The VRU function outputs roll and pitch by fusing accelerometer and gyroscope data. It is intended for dynamic attitude measurement without heading output. Under typical dynamic conditions, the algorithm reduces the effect of linear acceleration on roll and pitch estimation.

7.3 AHRS

The AHRS function outputs full 3D attitude, including roll, pitch, and heading. It fuses accelerometer, gyroscope, and, on supported models, magnetometer data. AHRS output is available only on supported models.

8 Interface and Pin Definitions

The HI18 connector is a standard M8 circular connector, with a male connector on the sensor side. In the following sections, SGND refers to the signal reference ground and is internally connected to GND. CAN GND refers to the shield/chassis reference ground and is connected to the enclosure. CAN GND is not intended for use as logic ground or power ground. Before wiring, determine whether to connect this reference ground according to the grounding scheme of the system.



Figure 3: HI18 M8 A-Coded Male Connector Pin Numbering

8.1 M8 8-Pin UART (TTL) Pin Definitions

Table 6: 8-Pin UART (TTL) Pin Definitions

No.	Color	Name	Type	Description	Remarks
1	White	SGND	Power	Signal GND	
2	Brown	Vs	Power	Power +	
3	Green	GND	Power	Power ground	
4	Yellow	RXD1	I	UART1 receive (TTL)	
5	Gray	TXD1	O	UART1 transmit (TTL)	
6	Pink	SGND	Power	Signal GND	
7	Blue	RXD2	I	UART2 receive (TTL), can receive GPRMC messages	
8	Red	I/O	I/O	Multi-function I/O, default synchronization input mode, can be connected to a PPS signal	

Note 1: For other functions of the I/O pin, refer to the Command and Programming Manual.

Note 2: SGND is internally connected to GND.

8.2 M8 8-Pin UART (RS-232) Pin Definitions

Table 7: 8-Pin UART (RS-232) Pin Definitions

No.	Color	Name	Type	Description	Remarks
1	White	SGND	Power	Signal GND	
2	Brown	Vs	Power	Power +	
3	Green	GND	Power	Power ground	
4	Yellow	RXD1	I	UART1 receive (RS-232)	
5	Gray	TXD1	O	UART1 transmit (RS-232)	
6	Pink	SGND	Power	Signal GND	
7	Blue	RXD2	I	UART2 receive (RS-232 level), can receive GPRMC messages	
8	Red	I/O	I/O	Multi-function I/O, default synchronization input mode, can be connected to a PPS signal	

Note 1: For other functions of the I/O pin, refer to the Command and Programming Manual.

Note 2: SGND is internally connected to GND.

8.3 M8 8-Pin MI1 (RS-232 + CAN) Pin Definitions

Table 8: 8-Pin MI1 (RS-232 + CAN) Pin Definitions

No.	Color	Name	Type	Description	Remarks
1	White	SGND	Power	Signal GND	
2	Brown	Vs	Power	Power +	
3	Green	GND	Power	Power ground	
4	Yellow	RXD1	I	UART1 receive (RS-232)	
5	Gray	TXD1	O	UART1 transmit (RS-232)	
6	Pink	CAN GND	Power	CAN shield/reference ground, connected to the enclosure; may be left floating if unused	
7	Blue	CAN H	AIO	CAN High	
8	Red	CAN L	AIO	CAN Low	

Note 1: CAN GND is the shield/chassis reference ground and is connected to the sensor enclosure. It may be left floating if unused. It must not be directly connected to power ground or signal ground.

9 Specifications

9.1 Gyroscope

Table 9: Gyroscope Specifications

Parameter	Product	Conditions	Min	Type	Max	Unit	Remarks
Range	HI18M0		±250			°/s	Default: ±2000
			±500				
			±1000				
			±2000				
Range	HI18S2/HI18S3		±250			°/s	Default: ±2000
			±500				
			±1000				
			±2000				
Digital Resolution	HI18M0		16		16	bit	
	HI18S2/HI18S3		16		20		
Scale Factor Error	HI18M0	Rotation at 100 °/s	<600		850	ppm	Type: RMS
	HI18S2/HI18S3	Rotation at 100 °/s	<600		1200		
Nonlinearity			±0.05			%FS	1
Noise Density	HI18M0	Bandwidth 47 Hz	0.014			°/s/√Hz	
	HI18S2/HI18S3	Bandwidth 10 Hz	0.0025				
3 dB Bandwidth	HI18M0		80		200	Hz	2
	HI18S2/HI18S3		80		400		
Zero-rate output			±0.1		±0.2	°/s	3, RMS
Sampling Rate			1000			Hz	
Bias Instability Allan variance	HI18M0	X	2.5		4	°/h	Type: 1σ Max: 3σ
		Y	3.2		5.5		
		Z	3		5.5		
Bias Instability Allan variance	HI18S2/HI18S3	X	4		6	°/h	Type: 1σ Max: 3σ
		Y	1.5		2.5		
		Z	1.7		4		
Bias Stability 10 s averaging	HI18M0	X	10		14	°/h	Type: 1σ Max: 3σ
		Y	13		17		
		Z	10		13		
Bias Stability 10 s averaging	HI18S2/HI18S3	X	10		16	°/h	Type: 1σ Max: 3σ
		Y	4		7		
		Z	5		13		
Bias Repeatability	HI18M0	X	20		36	°/h	Type: 1σ Max: 3σ
		Y	36		61		
		Z	16		25		
Bias Repeatability	HI18S2/HI18S3	X	11		35	°/h	Type: 1σ Max: 3σ
		Y	10		30		
		Z	9		20		

Angle Random Walk	HI18M0	X	0.55	1.1	%/ \sqrt{h}	Type: 1 σ Max: 3 σ
		Y	0.82	1.2		
		Z	0.47	0.7		
Allan variance	HI18S2/HI18S3	X	0.12	0.16	%/ \sqrt{h}	Type: 1 σ Max: 3 σ
		Y	0.1	0.12		
		Z	0.1	0.14		
Bias Drift over Temperature		-40 °C to 85 °C	0.07	0.15	°/s	4
g-Sensitivity		XYZ	0.05		°/s/g	

Note 1: Maximum deviation from the best-fit straight line within the specified range.

Note 2: Different modes have different bandwidths. The default 6-DoF mode is 80 Hz.

Note 3: After initial bias calibration, the bias can be estimated in real time by the algorithm engine.

Note 4: Measured using a thermal chamber and rate table in the Hipnuc laboratory, with a temperature ramp rate of less than 3 °C/min.

HI18 Series Datasheet

Compact, Waterproof IMU/VRU/AHRS Module

REV: 1.0

9.2 Accelerometer

Table 10: Accelerometer Specifications

Parameter	Product	Conditions	Min	Type	Max	Unit	Remarks
Range	HI18M0		±3			g	Default: ±12
			±6				
			±12				
	±24						
	HI18S2/HI18S3		±2			g	Default: ±16
			±8				
±16							
Digital Resolution	HI18M0		16		16	bit	
	HI18S2/HI18S3		16		20		
Initial Bias			1		2	mg	Type: RMS
Nonlinearity			±0.01			%FS	1
Noise Density	HI18M0	Bandwidth 10 Hz	0.16		0.2	mg/√Hz	
	HI18S2/HI18S3		0.05		0.07		
3 dB Bandwidth	HI18M0		90		200	Hz	2
	HI18S2/HI18S3		90		400		
Sampling Rate			1000			Hz	
Bias Instability Allan variance	HI18M0	X	0.021		0.035	mg	Type: 1σ Max: 3σ
		Y	0.032		0.065		
		Z	0.023		0.03		
	HI18S2/HI18S3	X	0.012		0.02	mg	Type: 1σ Max: 3σ
		Y	0.009		0.015		
		Z	0.016		0.022		
Bias Stability 10 s averaging	HI18M0	X	0.068		0.1	mg	Type: 1σ Max: 3σ
		Y	0.09		0.19		
		Z	0.07		0.1		
	HI18S2/HI18S3	X	0.032		0.055	mg	Type: 1σ Max: 3σ
		Y	0.022		0.032		
		Z	0.048		0.082		
Bias Repeatability	HI18M0	X	0.22		0.4	mg	Type: 1σ Max: 3σ
		Y	0.15		0.21		
		Z	0.12		0.2		
	HI18S2/HI18S3	X	0.1		0.3	mg	Type: 1σ Max: 3σ
		Y	0.06		0.2		
		Z	0.1		0.2		
Velocity Random Walk Allan Variance	HI18M0	XYZ	0.09		0.11	m/s/√h	Type: 1σ
HI18S2/HI18S3	XYZ	0.019		0.03	Max: 3σ		
Bias Variation over Temperature (-40 °C to 85 °C)	HI18M0	XYZ	2		5	mg	3
	HI18S2/HI18S3	XY	2		5		
		Z	6		15		

Note 1: Maximum deviation from the best-fit straight line within the specified range.

Note 2: Different modes have different bandwidths. The default 6-DoF mode is 90 Hz.

Note 3: Measured using a thermal chamber and rate table in the Hipnuc laboratory, with a temperature ramp rate of less than 3 °C/min.

9.3 Magnetometer

Table 11: Magnetometer Specifications

Parameter	Conditions	Min	Type	Max	Unit	Remarks
Range			±2000		μT	
Noise		0.19	0.45		μT	
Nonlinearity		±10	±20		μT	

9.4 Temperature Sensor Specifications

Table 12: Temperature Sensor Specifications

Parameter	Conditions	Min	Type	Max	Unit	Remarks
Range		-40	-	85	°C	
Offset Error			±5		°C	

9.5 Fusion Accuracy

Unless otherwise specified, the following attitude accuracy values are measured after factory calibration under typical installation conditions. Actual performance depends on installation conditions and calibration status, especially magnetic calibration where applicable.

Table 13: Attitude Accuracy

Parameter	Product	Conditions	Min	Type	Max	Unit	Remarks
Pitch/Roll (Static)				0.15	0.2	°	1
Pitch/Roll (Dynamic)				0.2	0.3	°	
Heading Accuracy (AHRS)				2	3	°	2
Static Heading Drift (6-DoF)		Static for 2 h		0.15	0.2	°	
Dynamic Heading Drift (6-DoF)	HI18M0			±10	±18	°	3
	HI18S2/HI18S3			±5	±10	°	
Heading Rotation Error (6-DoF)	HI18M0	100 °/s rotation		0.2	0.3	°	4
	HI18S2/HI18S3	100 °/s rotation		0.2	0.4	°	

Note 1: The data are referenced to the horizontal plane and are based on tests conducted on 20 samples.

Note 2: Measured after geomagnetic calibration in a magnetically undisturbed environment. The product must be configured in AHRS mode.

Note 3: Measured over 1 hour of operation on an indoor cleaning robot platform; results are given as 1σ. In 6-DoF mode, heading is an estimated value without magnetic reference. Its long-term stability is affected by initial alignment, motion conditions, environmental conditions, and time.

Note 4: Average error per revolution when the module rotates 10 cycles on a turntable.

9.6 Typical Usage Limits

- In 6-DoF mode, the heading angle drifts over time and is not suitable for long-term absolute heading holding.
- AHRS mode depends on the magnetic environment. Proximity to motors, permanent magnets, or high-current cable harnesses can affect heading accuracy.
- Attitude accuracy is affected by mounting flatness, mechanical stress, vibration, and linear acceleration.

4. For high-dynamic applications, validation is recommended after installation in the complete system.

10 System and Electrical Parameters

10.1 Electrical Parameters

Table 14: Electrical Parameters

Parameter	Conditions	Min	Type	Max	Unit	Remarks
Operating voltage range V_s		4.8	-	36	V	
Power consumption (24 V supply)	HI18M0			200	mW	
	HI18S2/HI18S3			220		
V_{OL}			-	0.4	V	
V_{OH}		2.6			V	
V_{IL}		-0.3		1	V	
V_{IH}		1.9		3.6	V	

Note 1: The UART (TTL) / I/O signal levels are independent of the supply voltage and must not be directly connected to logic levels above 5 V.

10.2 Interface Parameters

Table 15: Interface Parameters

Interface	Parameter	Min	Type	Max	Unit	Remarks
UART1	Baud rate	9600	115200	921600	bps	
	Output Data Rate	0	100	1000	Hz	
UART2 (RXD2)	Baud rate		115200		bps	Receives GPRMC messages
	Baud rate	125	500	1000	kbps	
CAN	Output Data Rate	0	100	200	Hz	
	Terminal resistor		Not built-in			No terminal resistor integrated inside the module

Note 1: Both the baud rate and output frame rate are configurable. The actual available output data rate depends on the output data content, message length, and communication configuration. For details, refer to the Command and Programming Manual.

10.3 System Parameters

Table 16: System Parameters

Parameter	Conditions	Value	Remarks
Dimensions		40 × 27 × 14 mm (including connector)	
Weight		<75 g	
System startup time		2 s	1
Screw specification		M2.5	
Operating temperature		-40 °C to 85 °C	
Enclosure material		Aluminum alloy	
Vibration resistance		1.0 mm (10 Hz to 58 Hz), ≤20 g (58 Hz to 600 Hz)	
Environmental compliance		Compliant with relevant RoHS requirements	2
Drop test		Free drop 3 times from a 75 cm-high lab bench	3
Temperature Shock Test		Temperature increased from -40 °C to 85 °C within 1 hour, repeated 5 times	3

Note 1: Time from power-on to valid data output.

Note 2: For other compliance materials, certifications, and conformity documents, refer to the latest official information.

Note 3: Factory/design verification test condition; does not represent the recommended long-term operating limit.

10.4 Absolute Maximum Ratings

Table 17: Absolute Maximum Ratings

Parameter	Limit	Description
Mechanical shock	2000 g	Duration < 0.2 ms
Storage temperature	-40 °C to 85 °C	
ESD (HBM)	30 kV	JEDEC/ESDA JS-001
Input voltage	40 V	
I/O to GND	3.6 V	
TXD (TTL) to GND	3.6 V	
RXD (TTL) to GND	3.6 V	
TXD (RS-232) to GND	±13.2 V	
RXD (RS-232) to GND	±24 V	
CAN_H, CAN_L to GND	±36 V	

Note 1: Exceeding the absolute maximum ratings may cause permanent damage to the device. Normal operation is not guaranteed under these conditions.

11 Mechanical Dimensions

11.1 HI18 M8 Mechanical Dimensions

All dimensions are in mm.

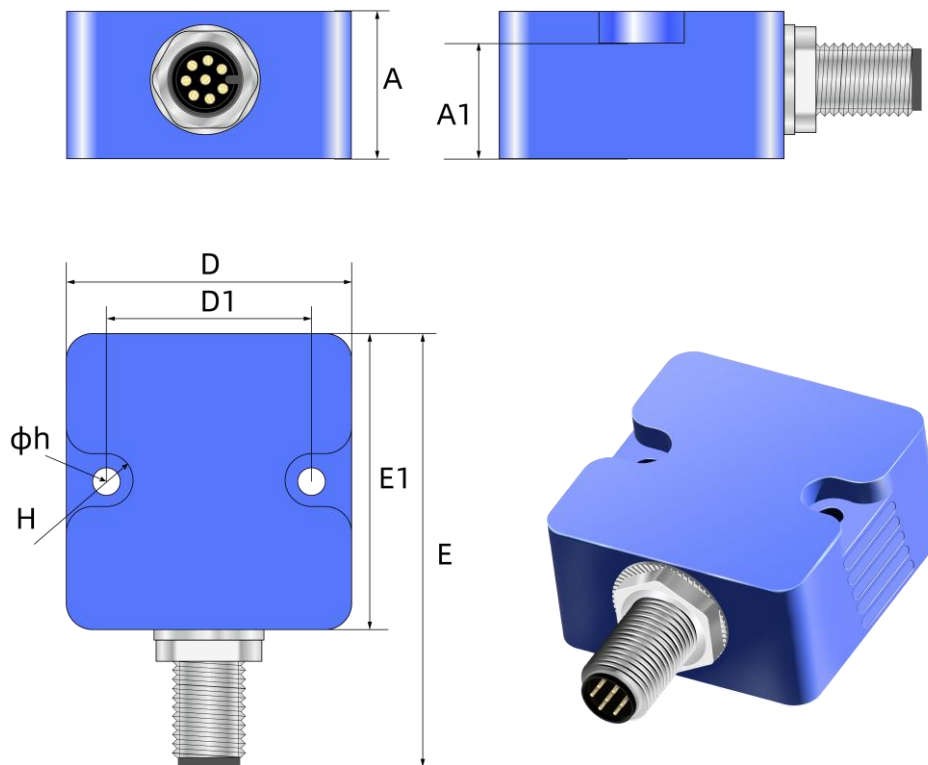

Figure 4: HI18 M8 Mechanical Dimensions

Table 18: HI18 M8 Dimensional Data

Symbol	Min (mm)	Type (mm)	Max (mm)
A	13.8	14	14.2
A1	10.8	11	11.2
D	26.8	27	27.2
D1	21.9	22	22.1
E	39	40	41
E1	27.8	28	28.2
H	R2.4	R2.5	R2.6
h	Φ2.55	Φ2.6	Φ2.65

11.2 IMU Center Location

The IMU is positioned symmetrically about the center of the blue housing. No sensor-to-housing offset needs to be considered.

12 Coordinate System

12.1 ENU (Default)

The body frame adopts the Right-Forward-Up (RFU) coordinate system, and the geodetic frame adopts the East-North-Up (ENU) coordinate system. The axes of acceleration and gyroscope are shown in the figure below:

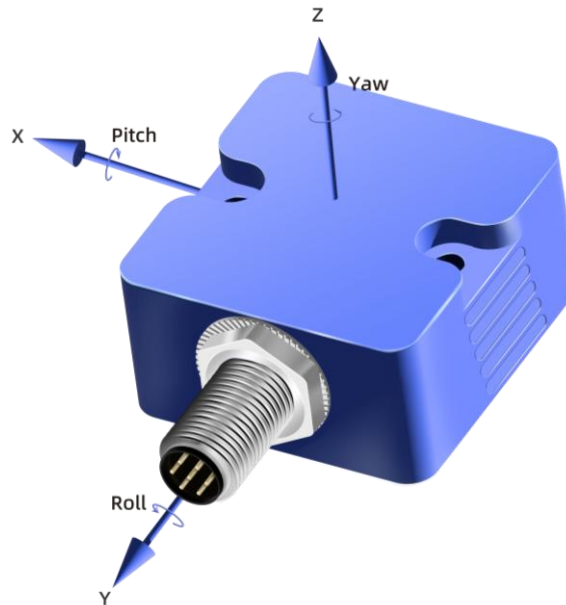

Figure 5: HI18 Coordinate System

The Euler angles are reported in the Z-X-Y (312) rotation sequence. The detailed definition is as follows:

- Rotation around the Z-axis: Heading Angle (Yaw, ψ); Range: $-180^\circ - 180^\circ$
- Rotation around the X-axis: Pitch Angle (θ); Range: $-90^\circ - 90^\circ$
- Rotation around the Y-axis: Roll Angle (ϕ); Range: $-180^\circ - 180^\circ$

When the module coordinate frame coincides with the reference coordinate frame, the ideal Euler angle outputs are Pitch = 0° , Roll = 0° , and Yaw = 0° .

The quaternion order, Euler angle definitions, and coordinate transformation conventions are defined in the Command and Programming Manual and shall prevail.

12.2 NWU and NED

The body frame can also be configured to the North-West-Up (NWU) or North-East-Down (NED) coordinate system. Users need to configure it independently. For details, refer to the Command and Programming Manual.

13 Installation

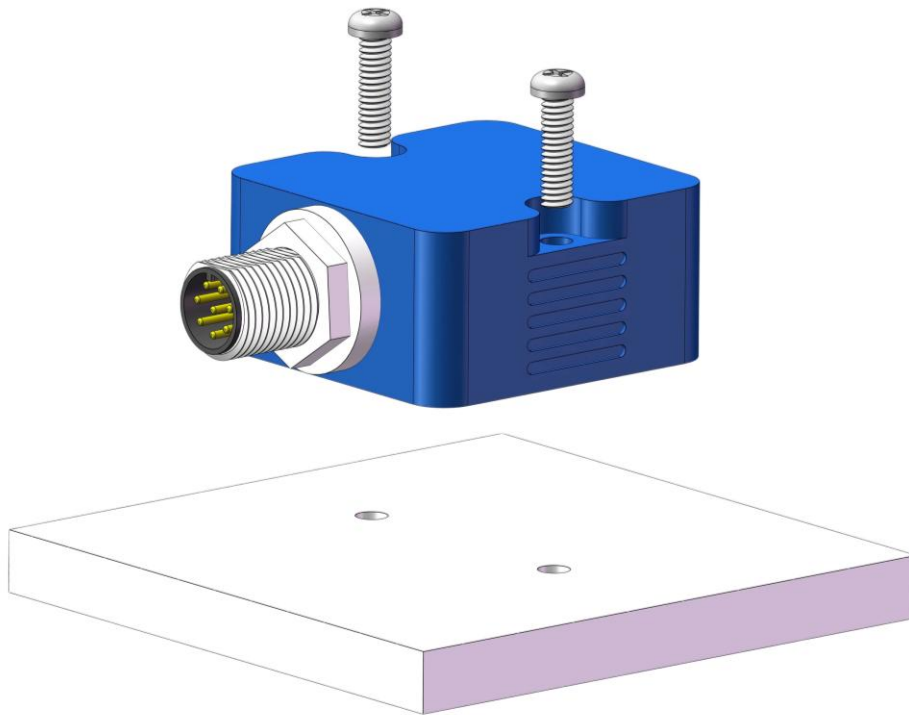

Figure 6: Installation Diagram

The following points shall be observed when installing the HI18:

1. The mounting surface should be as flat as possible and rigidly fixed.
2. Avoid installation near high-temperature heat sources.
3. Avoid continuous stress on the module caused by cable harness pulling.
4. AHRS models should be kept away from motors, speakers, permanent magnets, and high-current cable harnesses. It is recommended to perform magnetic calibration again after installation is completed.
5. For vibration conditions, actual system-level calibration and validation are recommended.

14 Cable

14.1 USB Type-A to M8 A-Coded Female Connector Cable (RS-232)



Figure 7: USB Type-A to M8 A-Coded Female Connector Cable (RS-232)

Note 1: The default cable length is 3.0 m, with a built-in USB-to-UART (RS-232) module.

14.2 USB Type-A to M8 A-Coded Female Connector Cable (TTL)



Figure 8: USB Type-A to M8 A-Coded Cable (TTL)

Note 1: The default cable length is 3.0 m, with a built-in USB-to-UART (TTL) module.

14.3 DB9 Female Connector + Flying Leads to M8 8-Pin A-Coded Female Connector Cable



Figure 9: DB9 Female Connector + Flying Leads to M8 A-Coded 8-Pin Cable

Note 1: The default cable length is 3.0 m.

14.4 Flying Leads to M8 8-Pin A-Coded Female Connector Cable



Figure 10: Flying Leads to M8 8-Pin A-Coded Female Connector Cable

Note 1: The default cable length is 3.0 m.

HI18 Series Datasheet

Compact, Waterproof IMU/VRU/AHRS Module

REV: 1.0

14.5 Applicable Products for Cables

Table 19: Applicable Products for Cables

Cable	Product	Remarks
USB Type-A to M8 A-Coded Female Connector Cable (RS-232)	HI18XX-USB(RS-232)-000 HI18XX-232-100	Built-in USB-to-UART (RS-232) module
USB Type-A to M8 A-Coded Female Connector Cable (TTL)	HI18XX-USB(TTL)-000 HI18XX-URT-100	Built-in USB-to-UART (TTL) module
DB9 Female Connector + Flying Leads to M8 8-Pin A-Coded Female Connector Cable	HI18XX-232-100	
Flying Leads to M8 8-Pin A-Coded Female Connector Cable	HI18XX-URT-100 HI18XX-232-100 HI18XX-MI1-000	MI1 interface: RS-232 + CAN

14.6 Default Factory-Supplied Cable

Table 20: Default Factory-Supplied Cable

Product	Cable
HI18XX-USB(RS-232)-000	USB Type-A to M8 A-Coded Female Connector Cable (RS-232)
HI18XX-USB(TTL)-000	USB Type-A to M8 A-Coded Female Connector Cable (TTL)
HI18XX-232-100	DB9 Female Connector + Flying Leads to M8 8-Pin A-Coded Female Connector Cable
HI18XX-URT-100	Flying Leads to M8 8-Pin A-Coded Female Connector Cable
HI18XX-MI1-000	Flying Leads to M8 8-Pin A-Coded Female Connector Cable

Note 1: The default cable length is 3.0 m. Please contact us if other cable types or custom cables are required.

15 How to Connect

15.1 UART (TTL / RS-232)

15.1.1 UART (TTL / RS-232) to USB



Figure 11: Wiring Diagram for UART (TTL / RS-232) to USB

15.1.2 UART (RS-232), DB9 Connector (Trigger Synchronization)

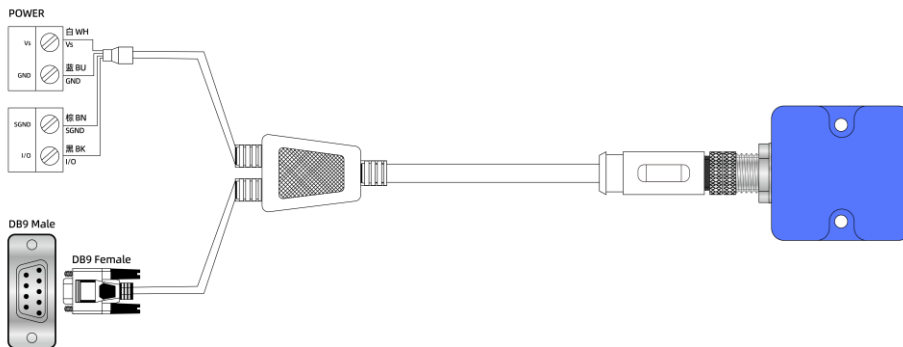

Figure 12: Wiring Diagram for UART (RS-232) Trigger Synchronization with DB9 Connector

Note 1: The I/O of the HI18 is configured as synchronous input mode by default. It can also be configured as synchronous output mode to serve as a Data Ready signal. For details, refer to the Command and Programming Manual.

15.1.3 UART (RS-232), DB9 Connector (PPS + GPRMC Synchronization)

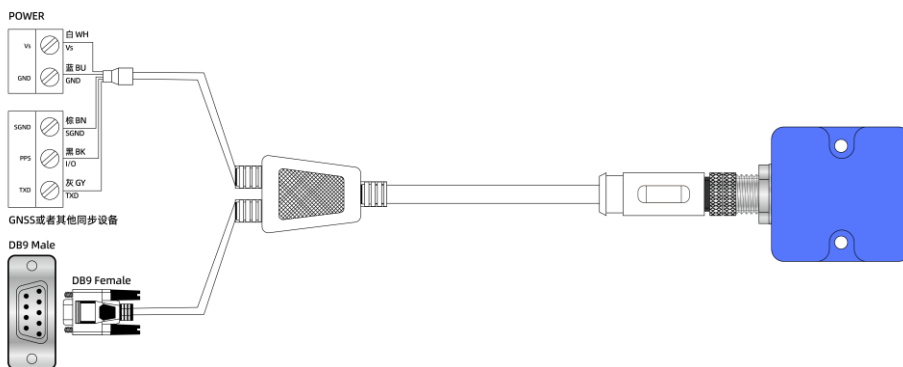

Figure 13: Wiring Diagram for UART (RS-232) PPS + GPRMC Synchronization with DB9 Connector

Note 1: The I/O of the HI18 operates in synchronous input mode in this configuration. The user's synchronization system shall provide PPS and GPRMC information. For details, refer to the Command and Programming Manual.

HI18 Series Datasheet

Compact, Waterproof IMU/VRU/AHRS Module

REV: 1.0

15.1.4 UART (TTL / RS-232), Flying Leads (Trigger Synchronization)

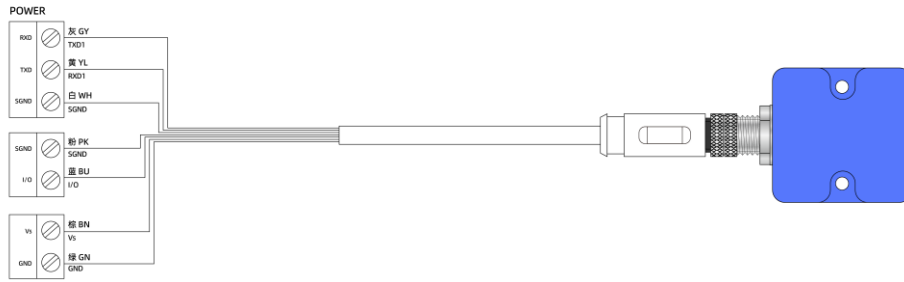

Figure 14: Wiring Diagram for UART (TTL / RS-232) Trigger Synchronization with Flying Leads

Note 1: SGND and GND are internally connected. If the user's synchronization system, power supply system, and data receiving system share a common ground, the SGND wiring may be reduced as appropriate, depending on which systems share the same ground.

15.1.5 UART (TTL / RS-232), Flying Leads (PPS + GPRMC Synchronization)

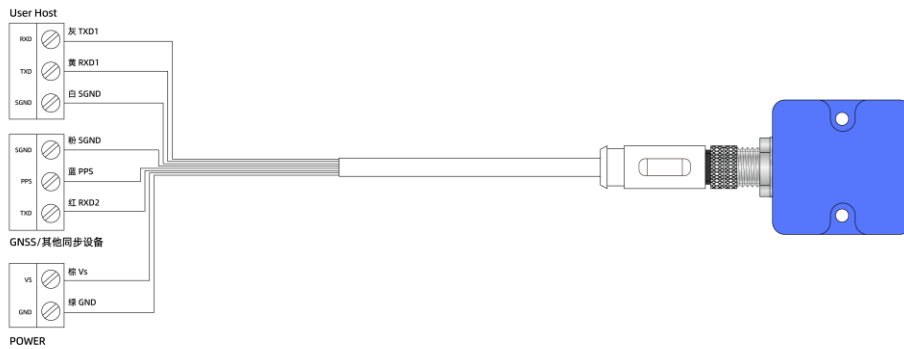

Figure 15: Wiring Diagram for UART (TTL / RS-232) PPS + GPRMC Synchronization with Flying Leads

Note 1: SGND and GND are internally connected. If the user's synchronization system, power supply system, and data receiving system share a common ground, the SGND wiring may be reduced as appropriate, depending on which systems share the same ground.

15.2 MI1 (RS-232 + CAN)

15.2.1 MI1 Interface, DB9 + Flying Leads Cable

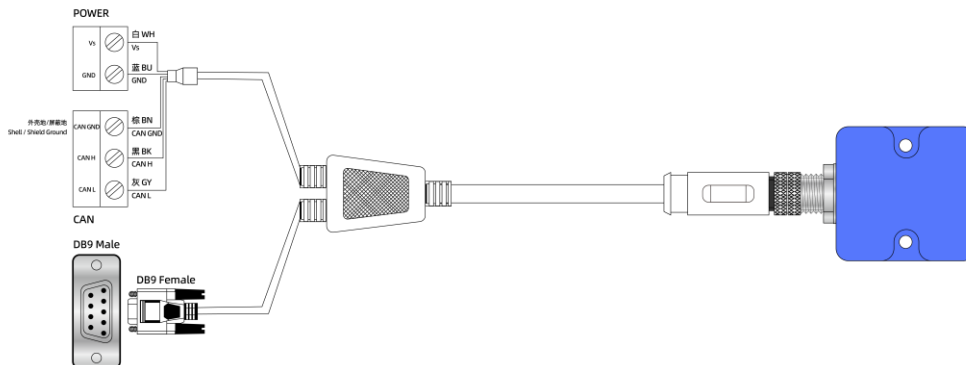

Figure 16: Wiring Diagram for MI1 (RS-232 + CAN) with DB9 Connector + Flying Leads

Note 1: CAN GND here is the CAN shield/chassis reference ground and is connected to the sensor housing. It may be left unconnected if not used. Do not connect it directly to power ground or signal ground.

15.2.2 MI1 Interface, Flying Leads Cable

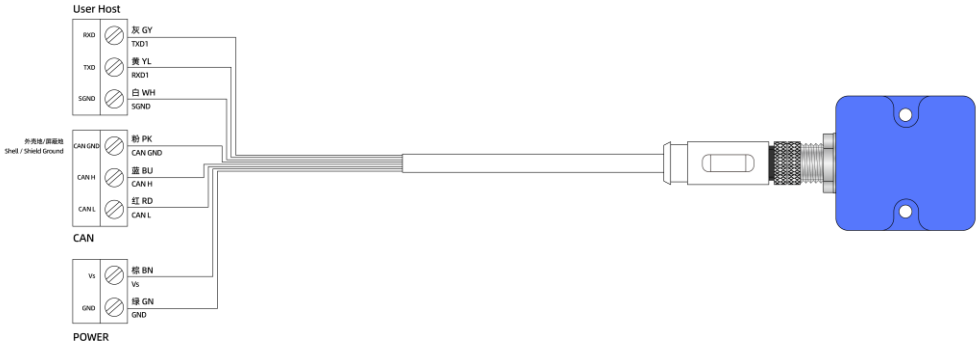

Figure 17: Wiring Diagram for MI1 (RS-232 + CAN) with Flying Leads

Note 1: CAN GND here is the shield/chassis reference ground and is connected to the sensor housing. It may be left unconnected if not used. Do not connect it directly to power ground or signal ground.

HI18 Series Datasheet

Compact, Waterproof IMU/VRU/AHRS Module

REV: 1.0

16 Default Configuration

Table 21: Default Configuration

Item	Product	Default Value	Remarks
UART		UART1	
Baud Rate		115200	
Frame Format		8N1	
Data Output Rate		100 Hz	
Default Protocol		Custom Binary Serial Protocol	
CAN Baud Rate		500 kbps	
Data Output Rate		100 Hz	
Default Protocol		SAE J1939	1
120 Ω Termination Resistor		None	
Coordinate System		ENU / RFU	
Gyroscope Range		± 2000 °/s	
Accelerometer Range	HI18M0	± 12 g	
	HI18S2/HI18S3	± 16 g	
Mode		6-DoF	
		Acceleration	
		Angular Rate	
Output Messages		Euler Angles	
		Quaternion	
		Temperature	
		Local Timestamp	

Note 1: The current factory-default CAN protocol is SAE J1939, applicable to firmware version 1.7.1 or later. Please contact us if CANopen is required.

17 Communication Protocols

17.1 Serial Binary Protocol

The product supports a serial binary communication protocol. For detailed message formats, output configuration, and command definitions, refer to the Command and Programming Manual.

17.2 CAN

The CAN interface supports CANopen and SAE J1939 communication for data output and interaction. For detailed message definitions, object mapping, or PGN allocation, refer to the Command and Programming Manual.

18 Disclaimer

The parameters listed in this document are typical values, maximum values, or test values under specified test conditions and do not constitute a final delivery commitment. Hipnuc reserves the right to make changes to the products, this document, and related information without prior notice. Final delivery specifications shall be subject to the order, technical agreement, or latest official documentation confirmed by both parties.