

1 Features

1.1 Hardware

- High-performance, low-noise MEMS IMU
- Integrated low-noise, high-reliability LDO
- Factory calibration and compensation over -40 °C to +85 °C, including bias, scale factor, and cross-axis calibration
- Available interface options: 2 × UART, UART + CAN, 3 × UART + CAN
- Support for PPS + GPRMC time synchronization
- Integrated temperature sensor
- Multi-function I/O for synchronization, data-ready, LED, alarm, and related functions
- Algorithm optimized for vibration environments
- Compact package: 22 × 22 × 10 mm
- Designed in compliance with RoHS-related requirements, Refer to the latest official compliance documents for certification status.
- Custom configurations available

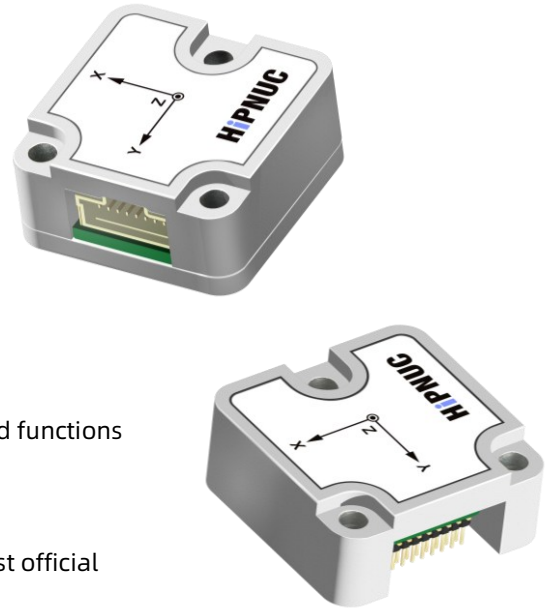

1.2 Software

- Adaptive EKF fusion algorithm
- The UART output data rate supports up to 1000 Hz, depending on output type and configuration, with low output latency
- Fusion algorithm optimized for dynamic attitude tracking and vibration suppression
- Improved robustness against attitude disturbance caused by linear acceleration under typical dynamic conditions
- Supports serial binary protocol, CAN, Modbus, and other communication protocols
- Rich user configuration commands
- Multifunctional GUI for easy operation
- Supports various examples for ROS1, ROS2, C, MATLAB, Python, Arduino, etc.

1.3 Key Specification Summary

Item	HI12M0	HI12H1	HI12H2	HI12S2	HI12S3
Function	IMU/VRU	IMU/VRU	IMU/VRU	IMU/VRU	IMU/VRU/AHRS
Magnetometer	×	×	×	×	√
Product Feature	Basic attitude sensing	Enhanced Z-axis gyro	Enhanced Z-axis gyro	Low-noise	Low-noise platform with magnetic heading reference
Interface	UART + CAN	UART + CAN	UART + CAN/ 3 × UART + CAN*	2 × UART/ UART + CAN	2 × UART/ UART + CAN
Size	22 × 22 × 10 mm (all series)				

- The above table is a series-level summary. Refer to Table 4 for standard part numbers.
- For UART, CAN, and synchronization support of different interface versions, refer to Table 3.
- CAN on models marked with * requires an external CAN transceiver.

2 Applications

The HI12 Series is intended for high-performance attitude sensing and complex operating conditions, suitable for attitude measurement and control under temperature variation, vibration, and dynamic motion. Typical applications include:

- Platform stabilization and control
- Construction machinery
- Humanoid robots
- Unmanned aerial vehicles (UAVs)
- Low-speed autonomous robots
- Smart agricultural machinery

3 Description

3.1 System Block Diagram

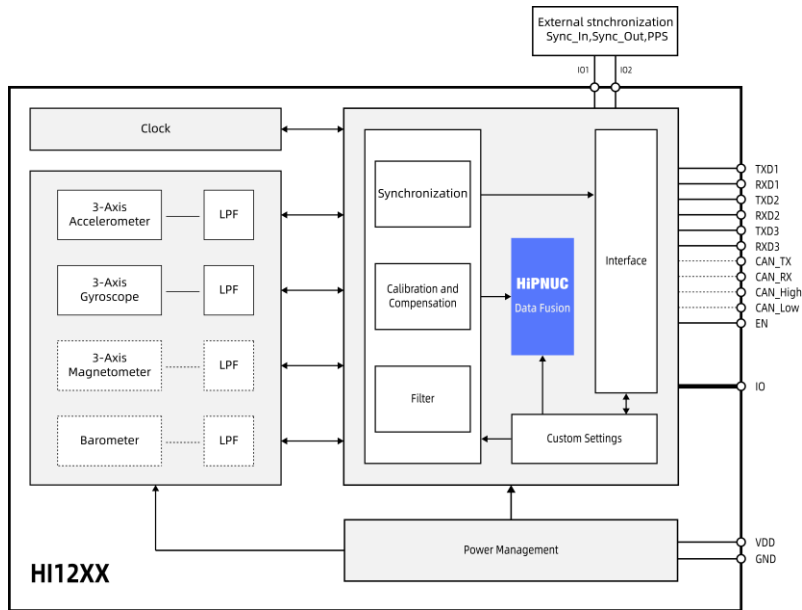

Figure 1: HI12 Series System Block Diagram

Note 1: Dashed lines indicate functions not supported by some models. Refer to Table 2: Product Selection Information for details.

3.2 Description

The HI12 Series is a MEMS IMU-based IMU / VRU / AHRS sensor module featuring in-house developed adaptive extended Kalman filtering, IMU noise dynamic analysis, and carrier motion state analysis algorithms. It provides users with raw inertial data, including: acceleration, angular rate, magnetic field, euler angles, quaternion. Depending on the model, the HI12 Series supports IMU, VRU, or AHRS functions. Not all models integrate a magnetometer or support AHRS output. Refer to Table 1 and Table 2 for detailed configuration.

Each module is factory calibrated and compensated for temperature, bias, scale factor, and cross-axis errors.

The module communicates through UART or CAN. The multifunction GUI software supports rapid evaluation, including module configuration, data visualization, firmware upgrade, and data logging.



Figure 2: GUI Software

Contents

1 Features	1
1.1 Hardware	1
1.2 Software	1
1.3 Key Specification Summary	1
2 Applications	2
3 Description	3
3.1 System Block Diagram	3
3.2 Description	3
4 Product Selection	6
5 Product Ordering	7
5.1 Ordering Code	7
5.2 Contact Information	7
6 Document Information	8
6.1 Revision History	8
6.2 Related Documents and Development Kits	8
7 HI12 System Architecture	9
7.1 IMU	9
7.2 VRU	9
7.3 AHRS	9
8 Interfaces and Pin Definitions	10
8.1 Molex MI0 Pin Definition	10
8.2 Molex MI1 Pin Definition	10
8.3 1.0 mm Board-to-Board Connector Pin Definition	11
9 Interfaces and Reference Designs	12
9.1 Power Supply	12
9.2 UART	12
9.3 CAN	12
9.4 Synchronization	13
9.4.1 HI12 Host-Triggered Synchronization (UART)	13
9.4.2 Host PPS+GPRMC Time Synchronization (UART)	13
9.4.3 External Device PPS+GPRMC Synchronization (UART)	13
9.4.4 CAN (Synchronization)	14
9.5 Reference Design BOM	14
10 Sensor Specifications	15
10.1 Gyroscope	15
10.2 Accelerometer	17
10.3 Magnetometer	19

- 10.4 Temperature Sensor 19
- 10.5 Fusion Accuracy 19
 - 10.5.1 Attitude Angle Accuracy..... 19
- 10.6 Typical Operating Limits 19
- 11 System and Electrical Specifications 20
 - 11.1 Electrical Specifications 20
 - 11.2 Interface Specifications 20
 - 11.3 System Specifications 20
 - 11.4 Absolute Maximum Ratings 21
- 12 Mechanical Dimensions 22
 - 12.1 HI12M0 / HI12H1 Dimensions and IMU Location 22
 - 12.2 HI12H2 / HI12SX Dimensions and IMU Location 22
 - 12.3 Board-to-Board Connector Footprint Dimensions 23
- 13 Installation 24
- 14 Coordinate System 25
 - 14.1 IMU/VRU/AHRS Coordinate System 25
 - 14.1.1 ENU (Default)..... 25
 - 14.1.2 NWU and NED 25
- 15 Cable Assemblies 26
- 16 Default Configuration 27
- 17 Communication Protocols..... 28
 - 17.1 Serial Binary Protocol..... 28
 - 17.2 Modbus 28
 - 17.3 CAN 28
- 18 Disclaimer 29

4 Product Selection

Table 1: Selection Information

HI12a-b-c-d					
Identifier	Series	a-Sensor Configuration	b-Data Interface	c - Connector	d- Other Information
HI	12	M0: IMU/VRU	MI0: 2 × UART / 3 × UART + CAN	0: Molex 5015680807	00: Default Other: Custom
		H1: IMU/VRU			
		H2: IMU/VRU	MI1: UART + CAN	1: 1.0 mm board-to-board	
		S2: IMU/VRU			
		S3: IMU/VRU/AHRS			

Note 1: For current standard models, refer to the Product Ordering section. Other models can be customized.

Note 2: HI12HX refers to HI12H1 and HI12H2; HI12SX refers to HI12S2 and HI12S3.

Note 3: CAN on the MI0 interface requires an external CAN transceiver.

Table 2: HI12 Series Module Configuration

Model	3-Axis Accelerometer	3-Axis Gyroscope	3-Axis Magnetometer	Enhanced Z-axis Gyro
HI12M0-MI1-000	√	√	×	×
HI12S2-MI0-000	√	√	×	×
HI12S3-MI0-000	√	√	√	×
HI12S2-MI1-000	√	√	×	×
HI12S3-MI1-000	√	√	√	×
HI12H1-MI1-000	√	√	×	√
HI12H2-MI1-000	√	√	×	√
HI12H2-MI0-100	√	√	×	√

Table 3: HI12 Interface Configuration

Model	UART	CAN	2 × Sync Pins (Multifunction I/O)
HI12M0-MI1-000	1 port	√	√
HI12S2-MI0-000	2 port	×	√
HI12S3-MI0-000	2 port	×	×
HI12S2-MI1-000	1 port	√	√
HI12S3-MI1-000	1 port	√	×
HI12H1-MI1-000	1 port	√	√
HI12H2-MI1-000	1 port	√	×
HI12H2-MI0-100	3 port	External CAN transceiver required	√

Note 1: Multifunction I/O is not limited to synchronization functions, and also supports LED, alarm, and other functions. Refer to the Command and Programming Manual for details.

5 Product Ordering

5.1 Ordering Code

Table 4: Ordering Code

Part Number	Name	Description
HI12M0-MI1-000	IMU/VRU Module	UART + CAN interface, Molex connector
HI12S2-MI0-000	IMU/VRU Module	2 × UART interface, Molex connector
HI12S3-MI0-000	IMU/VRU/AHRS Module	2 × UART interface, Molex connector
HI12S2-MI1-000	IMU/VRU Module	UART + CAN interface, Molex connector
HI12S3-MI1-000	IMU/VRU/AHRS Module	UART + CAN interface, Molex connector
HI12H1-MI1-000	IMU/VRU Module	UART + CAN interface, Molex connector, enhanced Z-axis gyro
HI12H2-MI1-000	IMU/VRU Module	UART + CAN interface, Molex connector, enhanced Z-axis gyro
HI12H2-MI0-100	IMU/VRU Module	3 × UART + CAN interface (external CAN transceiver required), board-to-board connector, enhanced Z-axis gyro

5.2 Contact Information

1. Email: overseas1@hipnuc.com
2. Website: www.hipnuc.com

6 Document Information

6.1 Revision History

Table 5: Revision History

Version	Date	Author	Description
1.0	July 23, 2024	Hipnuc	Initial release
1.1	November 27, 2024	Hipnuc	Added product models and notes; simplified synchronization description
1.2	December 28, 2024	Hipnuc	Model update
1.3	March 20, 2025	Hipnuc	Updated Allan parameters
1.4	August 28, 2025	Hipnuc	Added HI12SX series
1.5	March 17, 2026	Hipnuc	Corrected parameters and reformatted document

6.2 Related Documents and Development Kits

1. Command and Programming Manual
2. STEP / Package Files
3. Certification and compliance documents
4. GUI and reference examples

7 HI12 System Architecture

The HI12 Series is a sensor module supporting IMU, VRU, and AHRS functional configurations. Depending on the specific model, the product can provide outputs including: 3-axis accelerometer, 3-axis gyroscope, 3-axis magnetometer, euler angles, quaternion.

Depending on model configuration, the HI12 module may integrate: 3-axis accelerometer, 3-axis gyroscope, 3-axis magnetometer, high-performance processor, The controller is mainly used for: sensor synchronization, calibration, fusion algorithm processing, user configuration. Based on application scenarios and sensor characteristics, the module supports multiple modes such as: 6-DoF, AHRS, humanoid robot mode.

7.1 IMU

HI12 can be used as an inertial measurement unit (IMU) to provide users with precise 3D acceleration and 3D angular velocity data. These data are collected through the internally integrated high-precision accelerometer and gyroscope, and can reflect the motion state and dynamic changes of an object in three-dimensional space in real time. Compared with traditional IMU chips, the significant advantage of HI12 is that it has undergone strict calibration and compensation correction before leaving the factory, greatly improving the accuracy and stability of the output data. These calibrations include cross-axis, scale factor, bias, and temperature.

7.2 VRU

Through our self-developed algorithm fusion engine, HI12 can deeply process and optimize basic IMU data, thereby outputting high-precision 3D orientation data based on the gravity reference frame. These orientation data include pitch, roll, and yaw, providing users with intuitive and reliable attitude information support.

7.3 AHRS

Based on IMU and VRU, HI12 is further upgraded into a more powerful attitude and heading reference system (AHRS) by introducing a high-precision, wide-range TMR (tunnel magnetoresistance) 3-axis magnetometer. This upgrade significantly enhances HI12's attitude sensing capability, enabling it to provide users with more comprehensive and accurate attitude data, including long-term stable pitch, roll, and yaw based on magnetic north reference.

8 Interfaces and Pin Definitions

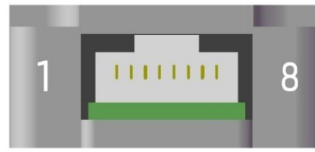

Figure 3: HI12 Molex Connector Pin Numbering

Note 1: The connector part number is Molex 5015680807. The mating connector is 501330-0800.

8.1 Molex MI0 Pin Definition

Table 6: Molex MI0 Pin Definition

Pin No.	Name	Type	Description	Remark
1	UART1_TXD	O	UART1 transmit	
2	UART1_RXD	I	UART1 receive, can accept external GNSS GPRMC	
3	UART2_TXD	O	UART2 transmit	
4	UART2_RXD	I	UART2 receive, can accept external GNSS GPRMC	
5	IO1 (SYNC_IN/PPS)	I/O	Sync input, can receive external trigger, e.g. GNSS PPS	
6	IO2 (SYNC_OUT)	I/O	Sync output, can be used as Data Ready	
7	GND	Power	Ground	
8	VDD	Power	Power input, 3.2 to 5 V	

8.2 Molex MI1 Pin Definition

Table 7: Molex MI1 Pin Definition

Pin No.	Name	Type	Description	Remark
1	UART1_TXD	O	UART1 transmit	
2	UART1_RXD	I	UART1 receive, can accept external GNSS GPRMC	
3	CAN_H	AIO	CAN High	
4	CAN_L	AIO	CAN Low	
5	IO1 (SYNC_IN/PPS)	I/O	Sync input, can receive external trigger, e.g. GNSS PPS	
6	IO2 (SYNC_OUT)	I/O	Sync output, can be used as Data Ready	
7	GND	Power	Ground	
8	VDD	Power	Power input, 3.2 to 5 V	

8.3 1.0 mm Board-to-Board Connector Pin Definition

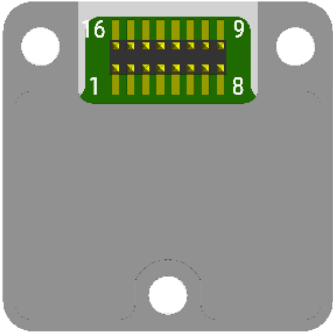

Figure 4: HI12 1.0 mm Board-to-Board Connector Pin Definition

Note 1: Connector specification: 2 × 8 pin, 1.0 mm pitch header; mating connector: 2 × 8 pin, 1.0 mm pitch socket.

Table 8: 1.0 mm Board-to-Board Connector Pin Definition

Pin No.	Name	Type	Description	Remark
1	VDD	Power	Power input, 3.2 to 5 V	
2	UART1_RXD	I	UART1 receive, can accept external GNSS GPRMC	
3	UART1_TXD1	O	UART1 transmit	
4	IO1 (SYNC_IN/PPS)	I/O	Sync input, can receive external trigger, e.g. GNSS PPS	
5	CAN_TX	O	CAN transmit	
6	CAN_RX	I	CAN receive	
7	UART3_RXD	I	UART3 receive, reserved UART	
8	UART3_TXD	O	UART3 transmit, reserved UART	
9	UART2_TXD	O	UART2 transmit	
10	UART2_RXD	I	UART2 receive, can accept external GPRMC information	
11	IO6	I/O	Reserved, leave floating	
12	IO5	I/O	Reserved, leave floating	
13	IO9	I/O	Reserved, leave floating	
14	IO2 (SYNC_OUT)	I/O	Sync output, can be used as data ready	
15	EN	I	Module enable, active high, internally pulled up; pull low to disable; can be left floating if unused	
16	GND	Power	GND	

Table 9: UART Function Description

Port	Data Transmission	Command Configuration	GPRMC	Firmware Upgrade
UART1(main UART)	√	√	√	√
UART2	√	√	√	×
UART3	×	×	√	×

9 Interfaces and Reference Designs

9.1 Power Supply

The module integrates an LDO to suppress the impact of input power noise on internal analog and digital circuits. The recommended input voltage range is 3.2 V to 5.0 V. For the operating voltage range, refer to 11.1 Electrical Parameters. External power supply can use LDO or DC/DC.

9.2 UART

The HI12 series sensor supports flexible and diverse communication methods, and can communicate through UART1/UART2 in full-duplex mode. By default, the communication frame format is standard 8N1 mode, namely:

- Baud rate: 115200 bps (adjustable as needed)
- Data bits: 8 bits
- Parity: none
- Stop bits: 1 bit

This communication configuration is a standard configuration in industrial applications, with strong compatibility, and can seamlessly interface with most embedded systems, industrial control devices, robot controllers, etc.

In addition, HI12 can also expand the UART interface into RS-485 or RS-422 communication by adding external RS-485 or RS-422 transceivers, further enhancing the applicability and scalability of the module.

Note 1: Both baud rate and data output frame rate can be modified through commands. Refer to the Command and Programming Manual for details.

When using the HI12 series sensor for UART communication, it is recommended that the logic level of the user's processor be 3.3 V. If communication with a processor of 5 V or 1.8 V logic level is required, the user needs to add a level shifting chip to ensure reliable communication and device safety.

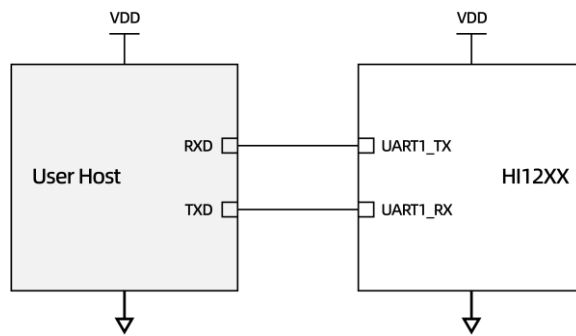

Figure 5: HI12 UART Communication Minimum System Reference Circuit

9.3 CAN

Models supporting CAN can implement the standard CAN 2.0B communication protocol. The default baud rate is 500 kbps, which can meet the needs of most industrial and embedded applications. Users can also modify the baud rate through commands to adapt to different communication scenarios. Refer to the Command and Programming Manual for details.

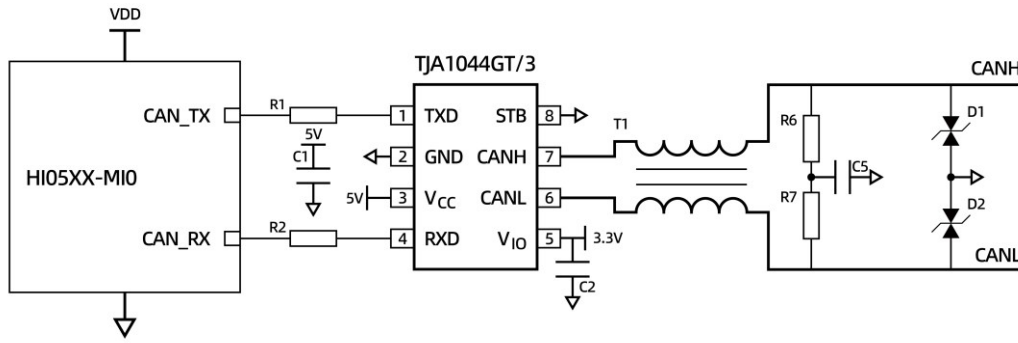

Figure 6: Board-to-Board Connector CAN Communication Reference Circuit

Note 1: Baud rate, ID, etc. can be modified through commands. Refer to the Command and Programming Manual for details.

Note 2: Terminal resistor configuration should be determined according to the system bus topology. R6/R7 in the reference circuit are for design reference only.

9.4 Synchronization

HI12 models supporting synchronization can implement pulse-trigger synchronization and PPS + GPRMC time synchronization, and can perform time alignment with the host or external devices (such as GNSS, cameras, radars, etc.). Refer to Table 3 for specific support.

9.4.1 HI12 Host-Triggered Synchronization (UART)

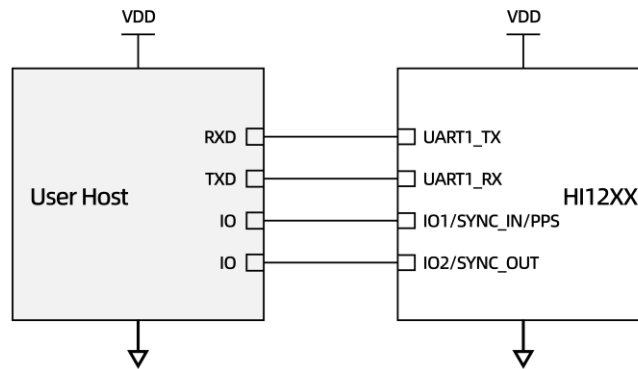

Figure 7: HI12 Host-Triggered Synchronization (UART Communication)

In this connection method, the user needs to directly connect IO1/IO2 to the host system for trigger synchronization between systems. If IO1 is used as synchronization input, then IO1 is in synchronization input mode, and the host needs to generate pulses with the same frequency as the data frame rate and send them to HI12. If IO2 is used, then IO2 needs to be in synchronization output mode, and the synchronization output pulse has the same frequency as the data frame rate and can be used as a Data Ready signal. IO1 and IO2 do not have to be used at the same time. The user can choose which synchronization method to use according to the specific system.

9.4.2 Host PPS+GPRMC Time Synchronization (UART)

In this connection method, the user needs to directly connect IO1/IO2 to the host system for inter-system time synchronization. At this time, IO1 is in synchronization input PPS mode, and the host needs to generate a PPS pulse per second to HI12. If IO2 is used, then IO2 needs to be in synchronization output mode, and the synchronization output pulse has the same frequency as the data frame rate and can be used as a Data Ready signal. UART1_RX shall receive the GPRMC message generated by the host.

9.4.3 External Device PPS+GPRMC Synchronization (UART)

HI12 can perform PPS+RMC time synchronization with external devices. The external device needs to generate PPS and RMC information. At this time, note that HI12, the user host, and GNSS must share a common ground. IO1 is responsible for receiving

the PPS pulse signal generated by the external device, and UART2_RX receives the RMC information.

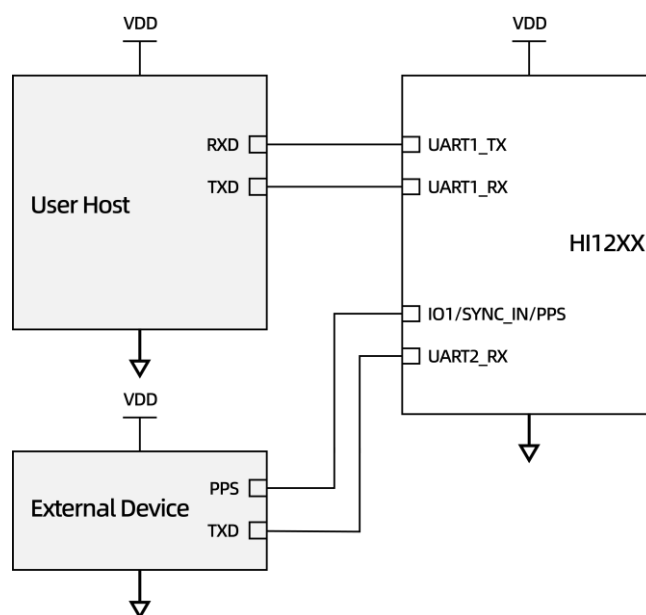

Figure 8: HI12 and External Device PPS+GPRMC Synchronization

9.4.4 CAN (Synchronization)

In CAN communication scenarios, synchronization can also be implemented. At this time, HI12 communicates with the host through the CAN interface, and the synchronization I/O can continue to be used for external triggering or time alignment. For specific synchronization timing and configuration methods, refer to the UART synchronization method.

9.5 Reference Design BOM

Table 10: Reference Design BOM

Item	Reference	Part	P/N	Vendor
Resistor	R6,R7	60.4 Ω	RC1206FR-0760R4L	YAGEO
Capacitor	C1,C2	0.1 μF	CC0402KRX5R7BB104	YAGEO
Capacitor	C5	1 nF	CC0402KRX7R9BB102	YAGEO
Common Choke	T1	5.8 kΩ @ 10 MHz, 100 μH @ 100 kHz, 150 mA	ACT45B-101-2P-TL003	TDK

Note 1: The voltage rating of the TVS device should be selected according to the system power platform. In multi-node cascaded scenarios, SMAJ series devices may also be selected.

10 Sensor Specifications

10.1 Gyroscope

Table 11: Gyroscope Specifications

Parameter	Product	Condition	Min	Typ	Max	Unit	Remark
Range	HI12M0			±250		°/s	Default: ±2000
				±500			
				±1000			
				±2000			
	HI12HX	X,Y	same as HI12M0			°/s	Default: ±2000
		Z		±400			Default: ±400
Resolution	HI12M0/HX HI12SX			±250		bit	
				±500			
				±1000			
				±2000			
Scale Factor Error		100 °/s rotation		±4000		ppm	Typical: RMS
				<600	850		
Nonlinearity				<600	1200	%FS	1
				±0.05			
Noise Density	HI12M0	Bandwidth 47 Hz		0.014		°/s/√Hz	
	HI12H1	X, Y Bandwidth 47 Hz		X,Y: 0.014			
		Z Bandwidth 80 Hz		Z: 0.005			
	HI12H2	X, Y Bandwidth 47 Hz		X,Y: 0.008			
Z Bandwidth 80 Hz			Z: 0.005				
3 dB Bandwidth	HI12M0/HX HI12SX			80	200	Hz	2
Zero-rate Output				80	400		
Sampling Rate				<± 0.1	±0.2	°/s	3,RMS
Bias Instability Allan Variance	HI12M0	X		2.5	4	°/h	Typical: 1σ; Max: 3σ
		Y		3.2	5.5		
		Z		3	5.5		
	HI12H1	X		2.5	4		
		Y		3.2	5.5		
		Z		2	3.5		
	HI12H2	X		1.5	2.5		
		Y		1.9	3.2		
		Z		2	3.5		
	HI12SX	X		2.2	5		
		Y		1.5	2.5		
		Z		1.7	4		

HI12 Series Datasheet

Compact IMU/VRU/AHRS Module

REV: 1.5

Bias Stability 10 s averaging	HI12M0	X	10	14	°/h	Typical: 1σ; Max: 3σ
		Y	13	17		
		Z	10	13		
	HI12H1	X	10	14		
		Y	13	17		
		Z	6	8		
	HI12H2	X	5.5	7		
		Y	7.5	9		
		Z	6	8		
HI12SX	X	6	14			
	Y	4	7			
	Z	5	13			
Bias Repeatability	HI12M0	X	20	36	°/h	
		Y	36	61		
		Z	16	25		
	HI12H1	X	20	36		
		Y	36	61		
		Z	9	20		
	HI12H2	X	11.5	21		
		Y	15	30		
		Z	9	20		
HI12SX	X	11	32			
	Y	10	30			
	Z	9	20			
Angle Random Walk (ARW) Allan Variance	HI12M0	X	0.55	1.1	°/√h	Typical: 1σ; Max: 3σ
		Y	0.82	1.2		
		Z	0.47	0.7		
	HI12H1	X	0.55	1.1		
		Y	0.82	1.2		
		Z	0.2	0.4		
	HI12H2	X	0.3	0.6		
		Y	0.4	0.7		
		Z	0.2	0.4		
HI12SX	X	0.12	0.16			
	Y	0.1	0.12			
	Z	0.1	0.14			
Bias Temperature Drift		-40 °C to 85 °C	0.07	0.15	°/s	4
g - Sensitivity		XYZ	0.05		°/s/g	

Note 1: Maximum deviation from the best-fit straight line within the specified range.

Note 2: Different modes have different bandwidths. The default 6-DoF mode is 80 Hz.

Note 3: After initial bias calibration, bias can be estimated in real time by the algorithm engine.

Note 4: Measured in Hipnuc laboratory environmental chamber and turntable, with heating ramp rate less than 3 °C/min.

10.2 Accelerometer

Table 12: Accelerometer Parameters

Parameter	Product	Condition	Min	Typ	Max	Unit	Remark
Range	HI12M0/HI12HX			±3			Default: ±12
				±6			
				±12			
				±24			
Resolution	HI12M0/HI12HX HI12SX			±2			Default: ±16
				±8		g	
				±16			
Initial Bias	HI12M0/HI12HX HI12SX			±32			Typical: RMS
				16	20	bit	
Nonlinearity				16			
3 dB Bandwidth	HI12M0/HI12HX HI12SX			1	2	mg	
Noise Density	HI12M0/HI12H1 HI12H2 HI12SX			0.01		%FS	1
				90	200	Hz	2
				90	400		
Sampling Rate	HI12M0/HI12H1			0.16	0.2	mg/√Hz	
				0.1	0.12		
			Bandwidth 10 Hz	0.05	0.07		
Bias Instability Allan Variance	HI12M0/HI12H1	X		1000		Hz	Typical: 1σ; Max: 3σ
		Y		0.021	0.035	mg	
		Z		0.032	0.065		
	HI12H2	X		0.015	0.02		
		Y		0.02	0.045		
		Z		0.015	0.02		
	HI12SX	X		0.012	0.02	mg	
		Y		0.009	0.015		
		Z		0.016	0.022		
Bias Stability 10 s averaging	HI12M0/HI12H1	X		0.068	0.1	mg	Typical: 1σ; Max: 3σ
		Y		0.09	0.19		
		Z		0.07	0.1		
	HI12H2	X		0.06	0.1		
		Y		0.055	0.15		
		Z		0.05	0.06		
HI12SX	X		0.032	0.055	mg		
	Y		0.022	0.032			
	Z		0.048	0.082			
Bias Repeatability	HI12M0/HI12H1	X		0.22	0.4	mg	Typical: 1σ Max: 3σ
		Y		0.15	0.21		
		Z		0.12	0.2		

HI12 Series Datasheet

Compact IMU/VRU/AHRS Module

REV: 1.5

Bias Repeatability	HI12H2	X	0.127	0.25	mg	Typical: 1σ Max: 3σ
		Y	0.09	0.15		
		Z	0.07	0.15		
	HI12SX	X	0.1	0.3		
		Y	0.06	0.2		
		Z	0.1	0.2		
Velocity Random Walk Allan Variance	HI12M0/HI12H1		0.09	0.11	m/s/√h	Typical: 1σ; Max: 3σ
	HI12H2		0.055	0.065		
	HI12SX		0.019	0.03		
Bias Temperature Drift -40 °C to 85 °C	HI12M0/HI12HX	XYZ	2	5	mg	3
		X,Y	2	5		
	HI12SX	Z	6	15		

Note 1: Maximum deviation from the best-fit straight line within the specified range.

Note 2: Different modes have different bandwidths; the default 6-DoF mode bandwidth is 90 Hz.

Note 3: Tested on the temperature chamber turntable of Hipnuc Laboratory, with a temperature rise rate less than 3 °C/min.

10.3 Magnetometer

Table 13: Magnetometer Specifications

Parameter	Condition	Min	Typ	Max	Unit	Remark
Range		-2000	±2000	2000	μT	
Noise		0.19	0.45		μT	
Nonlinearity		±10	±20		μT	

10.4 Temperature Sensor

Table 14: Temperature Sensor Specifications

Parameter	Condition	Min	Typ	Max	Unit	Remark
Range		-40	-	85	°C	
Offset Error			±5		°C	

10.5 Fusion Accuracy

Unless otherwise specified, the following fusion accuracy data are measured after factory calibration under typical installation conditions. Attitude accuracy is related to installation flatness, mechanical stress, vibration environment, linear acceleration, magnetic field environment, and user calibration status. Actual application results may vary.

10.5.1 Attitude Angle Accuracy

Table 15: Attitude Angle Accuracy

Parameter	Product	Condition	Min	Typ	Max	Unit	Remark
Pitch/Roll (Static)				0.1	0.15	°	1
Pitch/Roll (Dynamic)				0.2	0.3	°	
Heading (AHRS)				2	3	°	2
Heading Static Drift (6-DoF)		Static 2 h		0.15	0.2	°	
Heading Dynamic Drift (6-DoF)	HI12M0			10	18	°	3
	HI12HX/SX			5	10	°	
Heading Rotation Error (6-DoF)	HI12M0	100°/s rotation		0.2	0.3	°	4
	HI12HX/SX			0.2	0.4	°	

Note 1: Data are referenced to the calibration plane and obtained from 20 pcs test samples.

Note 2: Measured after magnetometer calibration and in the absence of surrounding magnetic interference; the product needs to be configured to AHRS mode.

Note 3: Measured on an indoor cleaning robot moving for 1 h, result is 1σ. In 6-DoF mode, heading is an estimate without magnetic reference, and its long-term stability is affected by initial alignment, operating conditions, environmental conditions, and time.

Note 4: Average per-turn error over 10 turns on a turntable.

10.6 Typical Operating Limits

1. In 6-DoF mode, heading drifts over time and is not suitable for long-term absolute heading hold.
2. AHRS mode depends on the magnetic environment. Motors, magnets, and high-current cables may degrade heading accuracy.
3. Attitude accuracy is affected by installation flatness, mechanical stress, vibration, and linear acceleration.
4. For high-dynamic applications, system-level validation after installation are recommended.

11 System and Electrical Specifications

11.1 Electrical Specifications

Table 16: Electrical Specifications

Parameter	Condition	Min	Typ	Max	Unit	Remark
Operating Voltage Range VDD		3.2	-	5.5	V	
Power Consumption	HI12M0			240	mW	
	HI12H1			245		
	HI12H2			300		
	HI12SX			240		
V _{OL}			-	0.4	V	
V _{OH}		2.6			V	
V _{IL}		-0.3		1	V	
V _{IH}		1.9		3.6	V	

11.2 Interface Specifications

Table 17: Interface Specifications

Interface	Parameter	Min	Typ	Max	Unit	Remark
UART1/UART2	Baud Rate	9600	115200	921600	bps	
	Output Data Rate	0	100	1000	Hz	
CAN	Baud Rate	125	500	1000	kbps	
	Output Data Rate	0	100	200	Hz	
	Differential Voltage		1.5	3	V	
	Termination Resistor		None			

11.3 System Specifications

Table 18: System Specifications

Parameter	Value	Remark
Dimensions	22 × 22 × 10 mm	
Weight	<11 g	
System Start-up Time	2 s	1
Operating Temperature	-40 °C to 85 °C	
Shield Material	Aluminum alloy	
Vibration Resistance	1.0 mm (10 Hz ~ 58 Hz), ≤20 g (58 Hz ~ 600 Hz)	
Environmental Compliance	Complies with relevant RoHS requirements	
Compliant materials	Refer to the latest official information for relevant certification and compliance documents	
Drop Test	Free drop 3 times from a 75 cm lab bench	
Temperature Shock Test	Temperature rises from -40 °C to 85 °C within 1 h, repeated 5 times	
Moisture Sensitivity Level (MSL)	MSL2	

Note 1: Time from power-up to valid data output.

11.4 Absolute Maximum Ratings

Table 19: Absolute Maximum Ratings

Parameter	Limit	Comment
Mechanical Shock	2000 g	Duration < 0.2 ms
Storage Temperature	-40 °C to 125 °C	
ESD (Human Body Model)	15 kV	JEDEC/ESDA JS-001
Input Voltage	9 V	
I/O to Ground Voltage	3.6 V	
CAN_H or CAN_L to Ground Voltage	±36 V	

12 Mechanical Dimensions

All dimensions are in mm.

12.1 HI12M0 / HI12H1 Dimensions and IMU Location

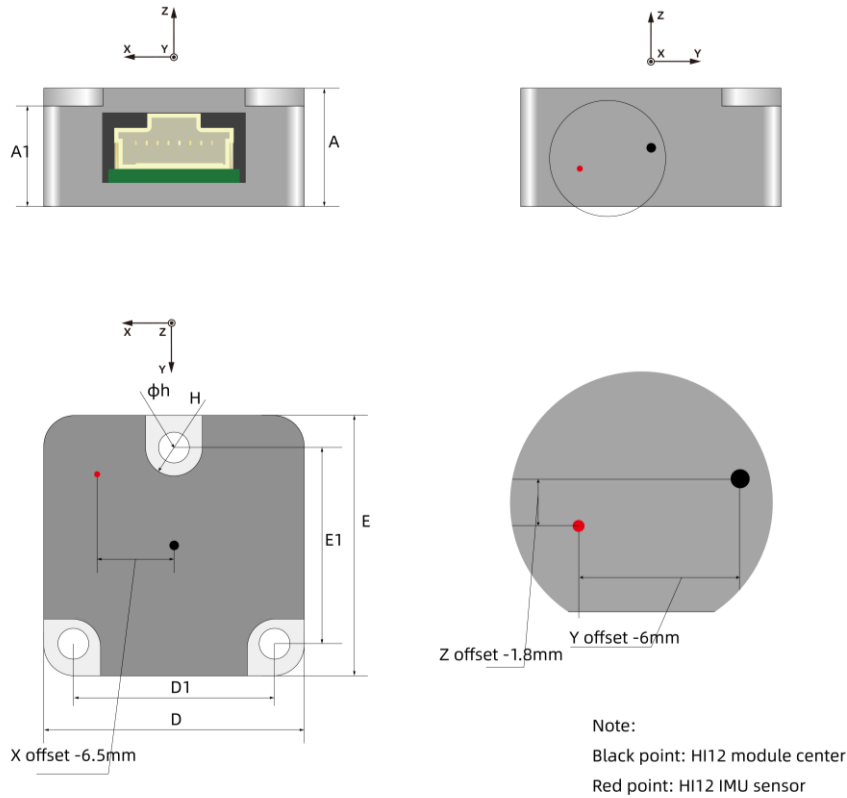

Figure 9: HI12M0 / HI12H1 Mechanical Dimensions and IMU Location

12.2 HI12H2 / HI12SX Dimensions and IMU Location

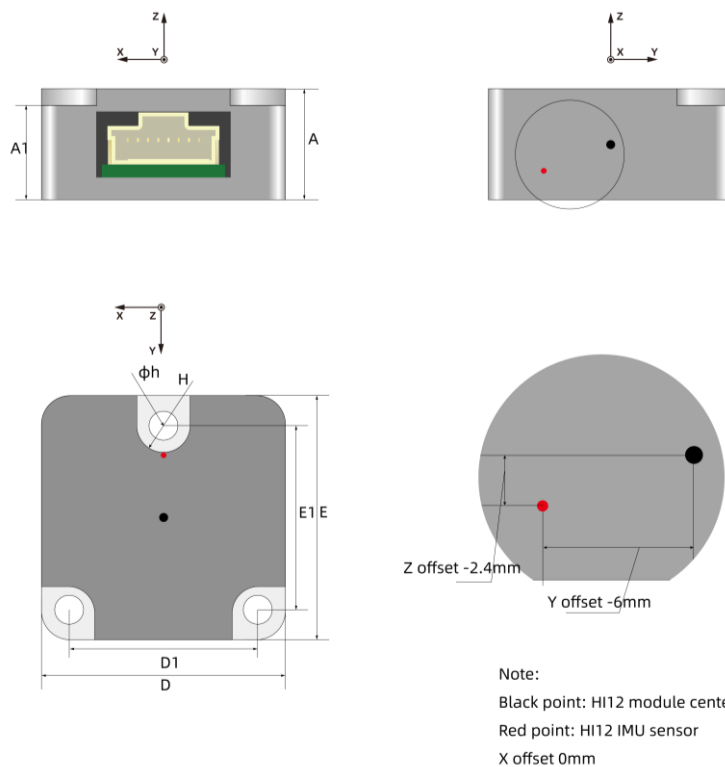

Figure 10: HI12H2 / HI12SX Mechanical Dimensions and IMU Location

Table 20: Product Dimension Data

Symbol	Min (mm)	Typ (mm)	Max (mm)
A	9.8	10	10.2
A1	8.3	8.5	8.7
D	21.8	22	22.2
D1	16.9	17	17.1
E	21.8	22	22.2
E1	16.5	16.6	16.7
H	R2.3	R2.4	R2.5
h	Φ2.55	Φ2.6	Φ2.65

12.3 Board-to-Board Connector Footprint Dimensions

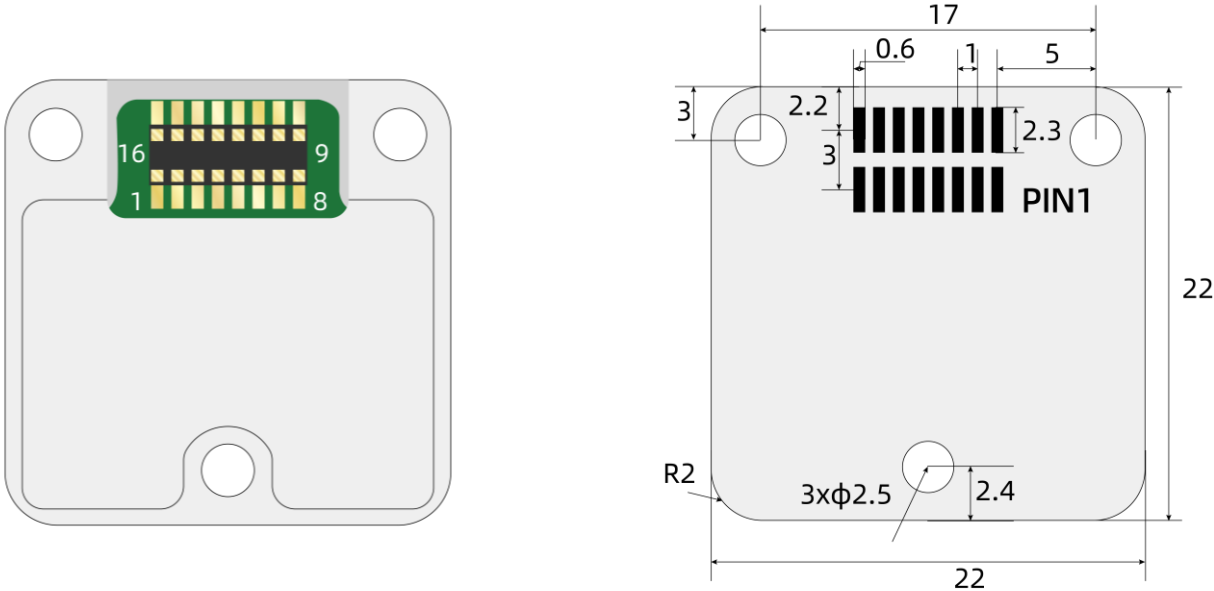

Figure 11: HI12 Board-to-Board Connector Footprint Dimensions

13 Installation

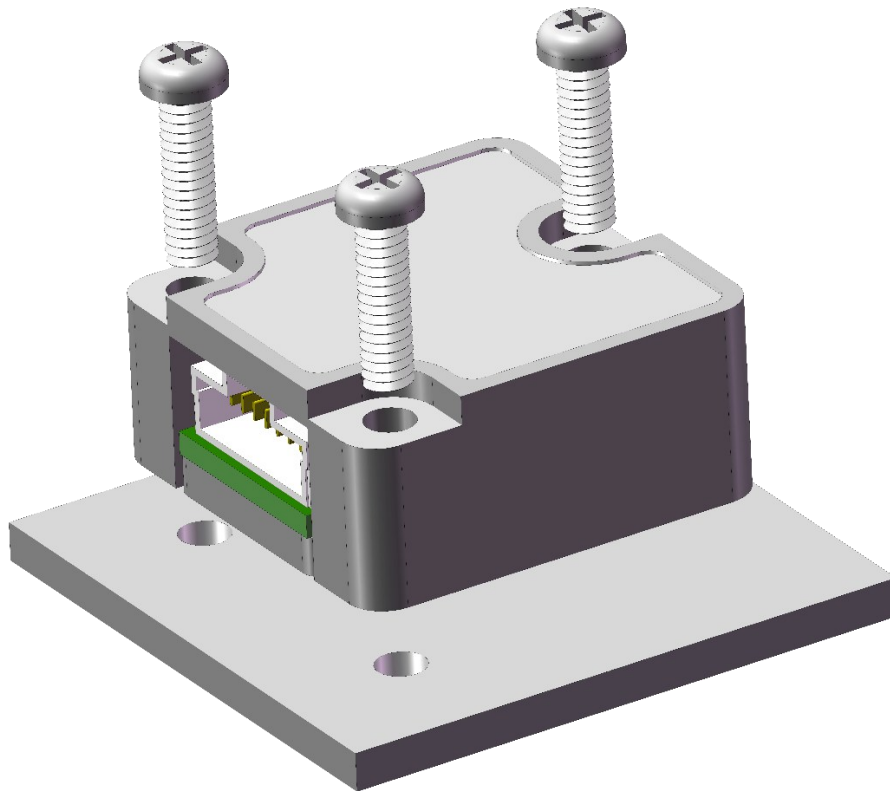

Figure 12: Installation Diagram

The following precautions should be noted during HI12 installation:

- The mounting surface should be as flat and rigid as possible
- Avoid installation near high-temperature heat sources
- Avoid continuous stress on the module caused by cable harness pulling
- For AHRS models, keep away from motors, speakers, magnets, and high-current harnesses; magnetic calibration after final installation is recommended
- For vibration-prone environments, system-level validation is recommended

14 Coordinate System

14.1 IMU/VRU/AHRS Coordinate System

14.1.1 ENU (Default)

The body frame uses the right-forward-up (RFU) coordinate system, and the navigation frame uses the east-north-up (ENU) coordinate system. The accelerometer and gyroscope axis directions are shown in the figure below:

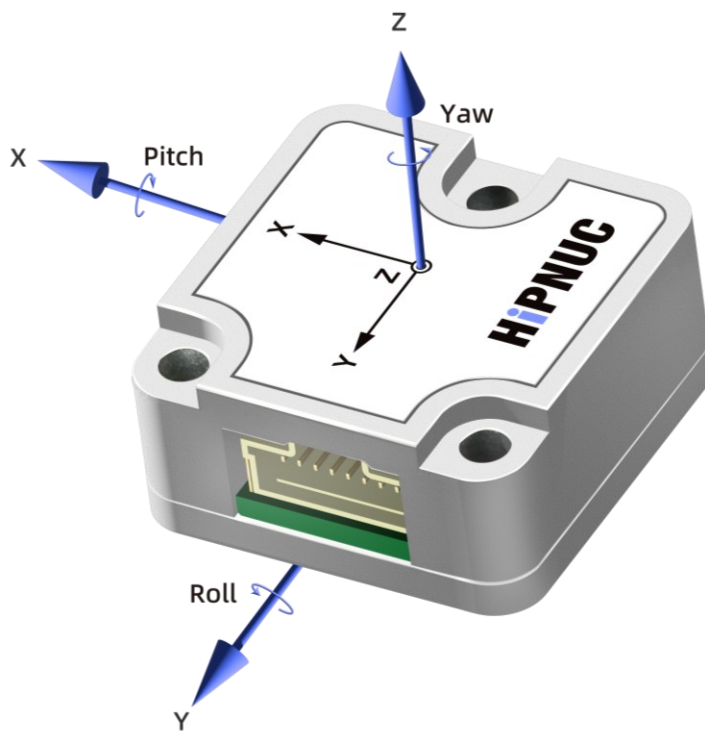

Figure 13: HI12 Coordinate System

The positive direction of angular velocity follows the right-hand rule. The quaternion output order is defined in the Command and Programming Manual. The Euler angle outputs correspond to yaw, pitch, and roll, and the rotation order uses the Z-X-Y (312) convention. For definitions involving intrinsic/extrinsic rotations and coordinate transformations, refer to the Command and Programming Manual. The specific definitions are as follows:

- Rotation about Z-axis: Yaw, range: $-180^\circ \sim 180^\circ$
- Rotation about X-axis: Pitch, range: $-90^\circ \sim 90^\circ$
- Rotation about Y-axis: Roll, range: $-180^\circ \sim 180^\circ$

When the module coordinate system coincides with the reference coordinate system, the ideal Euler angle outputs are Pitch = 0° , Roll = 0° , and Yaw = 0° .

For coordinate system rotation, refer to the Command and Programming Manual.

14.1.2 NWU and NED

The carrier can also be configured to the north-west-down (NWD) / north-east-down (NED) coordinate system. This needs to be configured by the user. Refer to the Command and Programming Manual for details.

15 Cable Assemblies



Figure 14: USB-to-Molex A (501330-0800) Cable Assembly

Note 1: Cable length: 1.0 m

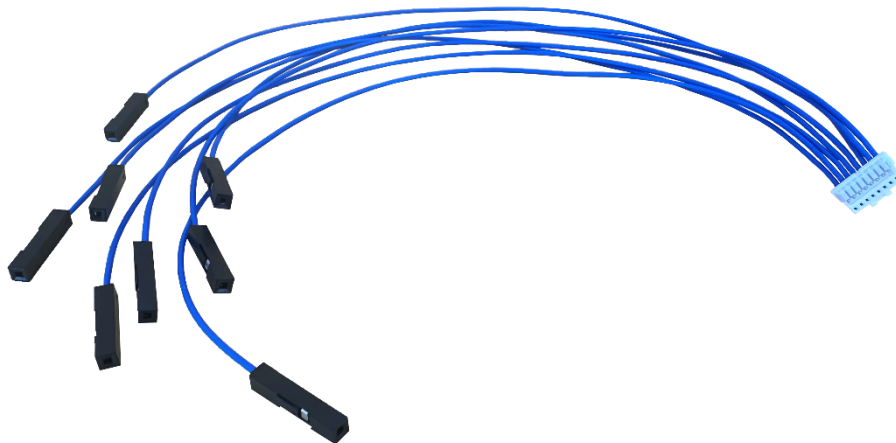

Figure 15: 501330-0800 to Dupont Cable Assembly

Note 2: Cable length: 30 cm

16 Default Configuration

Item	Product	Default Value	Remark
Communication Port		UART1	
Baud Rate		115200	
UART Configuration		8N1	
Output Data Rate		100 Hz	
CAN Baud Rate		500 kbps	
Coordinate System		ENU / RFU	
Gyro Range	HI12M0 / HI12SX	± 2000 °/s	
	HI12H1 / HI12H2	XY: ± 2000 °/s, Z: ± 400 °/s	
Accelerometer Range	HI12M0 / HI12HX	± 12 g	
	HI12SX	± 16 g	
Mode		6-DoF	
Output Content		Acceleration, angular rate, Euler angles, quaternion, temperature, local timestamp	

17 Communication Protocols

17.1 Serial Binary Protocol

The product supports a serial binary communication protocol. For specific message formats, output configuration, and command definitions, refer to the Command and Programming Manual.

17.2 Modbus

By adding an external RS-485 transceiver, Modbus RTU-based communication can be supported. For detailed protocol information, refer to the Command and Programming Manual.

17.3 CAN

CAN communication supports CANopen and SAE J1939. For detailed protocol definitions, please refer to the Command and Programming Manual for more details.

18 Disclaimer

The parameters, descriptions, and application information in this document are for product selection and design reference only, and do not constitute a final delivery commitment or quality guarantee. The suitability of the product must be evaluated by the user according to the specific application. Unless otherwise agreed in writing by both parties, Hipnuc shall not be liable for any direct or indirect loss caused by the use, interpretation, or reliance on this document. Hipnuc reserves the right to modify products, documents, and related information without prior notice.