

1 Features

1.1 Hardware

- High-performance, low-noise MEMS IMU
- Supports a wide input voltage range up to 48 V
- IP67-rated waterproof protection
- Multiple interface options are available, including USB, UART (TTL / RS-232), RS-485, RS-422, and RS-232 + CAN
- Supports pulse triggering and PPS + GPRMC time synchronization
- Multi-function I/O for synchronization, alarm signaling, and user-defined functions
- Factory-calibrated and temperature-compensated over the full temperature range from -40 °C to 85 °C, including bias, scale factor, and cross-axis compensation
- Integrated temperature sensor
- The product design complies with applicable RoHS requirements. For information on other compliance documentation and certification status, refer to the latest official documentation.
- Customization options are available



1.2 Software

- Adaptive EKF sensor fusion algorithm
- Supports output rates up to 1000 Hz, depending on configuration, with low output latency.
- Fusion algorithm optimized for dynamic attitude tracking and vibration suppression
- Under typical dynamic operating conditions, the fusion algorithm reduces the effect of linear acceleration on attitude estimation
- Supports serial binary, Modbus RTU, and CAN communication protocols
- Comprehensive command set for user configuration
- GUI software for convenient configuration and debugging
- Reference examples are available for ROS 1, ROS 2, C, MATLAB, Python, Arduino, and other platforms



1.3 Key Specifications Summary

Summary by product family grouping (for parameter classification only)

Table 1: Key Specifications Summary

Item	HI14M0	HI14RX	HI14SX
Function	IMU/VRU	R2: IMU/VRU; R3/R5: IMU/VRU/AHRS	S2: IMU/VRU; S3/S5: IMU/VRU/AHRS
Magnetometer	None	R2: None, R3/R5: Yes	S2: None, S3/S5: Yes
Features	Entry-level solution for basic attitude sensing	High-performance solution for improved stability	High-performance, low-noise solution for high-resolution applications
Interface	Entire series: USB, UART (TTL / RS-232), RS-485, RS-422, and RS-232 + CAN		
Dimensions	All M12 connector models: 59 × 40 × 20 mm (including connector length); housing size: 45 × 40 × 20 mm All PG flying-lead models: 40 × 36 × 16.5 mm (excluding cable)		

Note 1: In this document, HI14RX collectively refers to HI14R2, HI14R3, and HI14R5, while HI14SX collectively refers to HI14S2, HI14S3, and HI14S5. These grouping terms are used only for parameter classification and are not standalone orderable part numbers.

2 Applications

The HI14 series is designed for high-performance attitude sensing in demanding operating conditions and is suitable for attitude measurement and control in environments involving temperature variation, vibration, and dynamic motion. Typical applications include:

- service robots
- humanoid robots
- low-speed autonomous mobile robots
- smart agricultural machinery

3 Description

3.1 System Block Diagram

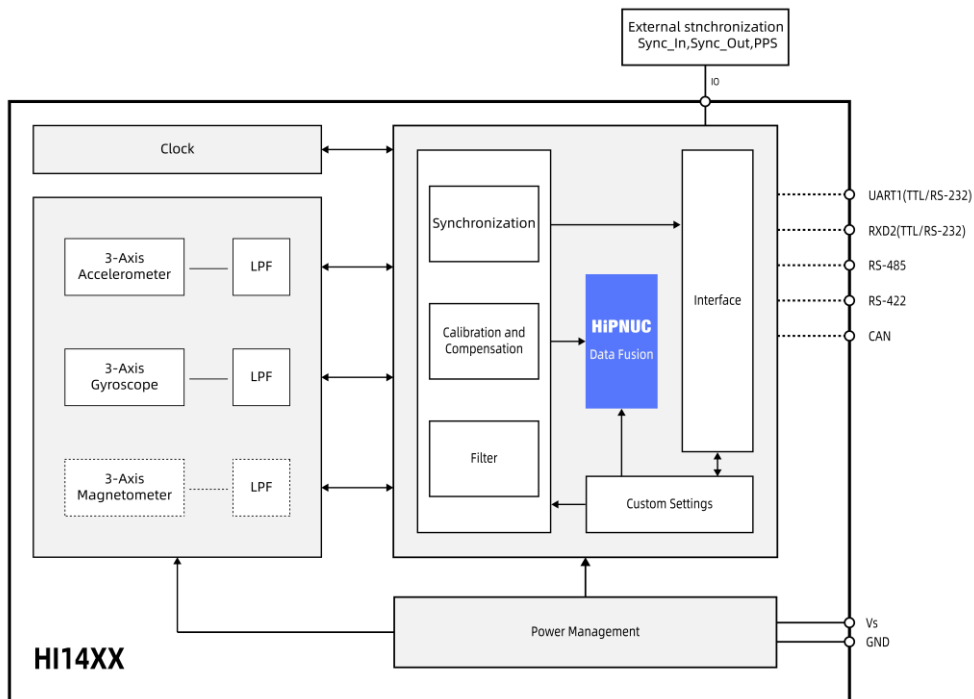

Figure 1: HI14 Series System Block Diagram

Note 1: Dashed lines indicate functions not supported by certain models; refer to Table 1 for details.

3.2 General Description

The HI14 series is a MEMS-based IMU/VRU/AHRS sensor module featuring proprietary adaptive extended Kalman filtering, dynamic IMU noise analysis, and motion-state analysis algorithms. It provides raw inertial data, including acceleration and angular rate, and, on supported models, magnetic field data, as well as computed attitude outputs such as Euler angles and quaternions. Depending on the model, the HI14 series supports IMU, VRU, or AHRS functions. Not all models integrate a magnetometer or support AHRS output; refer to Table 1 and 2 for specific configurations.

Each module is calibrated before shipment for bias, scale factor, and cross-axis compensation, and is temperature-compensated across the specified temperature range.

Data can be transmitted via UART (TTL / RS-232), CAN, RS-485, RS-422, or USB. The accompanying GUI software supports parameter configuration, data visualization, firmware upgrade, and data logging. Models differ in magnetometer availability, AHRS support, synchronization capability, and interface configuration. Refer to Table 1 and 2 and the specific ordering code for

the exact configuration of each model.



Figure 2: GUI Software

Contents

1 Features	1
1.1 Hardware	1
1.2 Software	1
1.3 Key Specifications Summary	1
2 Applications	2
3 Description	2
3.1 System Block Diagram.....	2
3.2 General Description	2
4 Product Selection	7
5 Ordering Information	8
5.1 HI14 M12 Connector Ordering Codes.....	8
5.2 HI14 PG Ordering Codes	10
5.3 Contact Information.....	10
6 Document Information	11
6.1 Revision History.....	11
6.2 Related Documents	11
7 HI14 System Architecture.....	12
7.1 IMU	12
7.2 VRU	12
7.3 AHRS	12
8 Interface and Pin Definitions	13
8.1 M12 5-Pin Definitions	13
8.1.1 M12 5-Pin UART (TTL) Pin Definitions	13
8.1.2 M12 5-Pin UART (RS-232) Pin Definitions	13
8.1.3 M12 5-Pin RS-485 Pin Definitions	13
8.1.4 M12 5-Pin CAN Pin Definitions.....	14
8.2 M12 8-Pin Definitions.....	14
8.2.1 M12 8-Pin UART (TTL) Pin Definitions	14
8.2.2 M12 8-Pin UART (RS-232) Pin Definitions	15
8.2.3 M12 8-Pin MI1 (RS-232 + CAN) Pin Definitions	15
8.2.4 M12 8-Pin RS-422 Pin Definitions	15
8.3 PG Pin Definitions	16
9 Specifications	17
9.1 Gyroscope	17
9.2 Accelerometer	20
9.3 Magnetometer.....	22
9.4 Temperature Sensor Specifications.....	22

- 9.5 Fusion Accuracy 22
- 9.6 Typical Usage Limits 22
- 10 System and Electrical Parameters..... 23
 - 10.1 Electrical Parameters..... 23
 - 10.2 Interface Parameters..... 23
 - 10.3 System Parameters 24
 - 10.4 Absolute Maximum Ratings 24
- 11 Mechanical Dimensions..... 25
 - 11.1 HI14 M12 Mechanical Dimensions 25
 - 11.2 HI14 PG Mechanical Dimensions 26
- 12 Coordinate System 27
 - 12.1 ENU (Default) 27
 - 12.2 NWU and NED 27
- 13 Installation 28
- 14 Cable 29
 - 14.1 USB Type-A to M12 A-Coded Female Connector Cable (RS-232) 29
 - 14.2 USB Type-A to M12 A-Coded Female Connector Cable (TTL)..... 29
 - 14.3 DB9 Female Connector + Flying Leads to M12 5-Pin A-Coded Female Connector Cable 29
 - 14.4 DB9 Female Connector + Flying Leads to M12 8-Pin A-Coded Female Connector Cable 29
 - 14.5 Flying Leads to M12 5-Pin A-Coded Female Connector Cable 29
 - 14.6 Flying Leads to M12 8-Pin A-Coded Female Connector Cable..... 29
 - 14.7 Applicable Products for Cables 30
 - 14.8 Default Factory-Supplied Cable 30
 - 14.9 PG 30
- 15 How to Connect..... 31
 - 15.1 UART (TTL / RS-232)..... 31
 - 15.1.1 UART (TTL / RS-232) to USB 31
 - 15.1.2 UART (RS-232), DB9 Connector..... 31
 - 15.1.3 UART (RS-232), DB9 Connector (Trigger Synchronization)..... 31
 - 15.1.4 UART (RS-232), DB9 Connector (PPS + GPRMC Synchronization) 32
 - 15.1.5 UART (TTL / RS-232), Flying Leads..... 32
 - 15.1.6 UART (TTL / RS-232), Flying Leads (Trigger Synchronization)..... 32
 - 15.1.7 UART (TTL / RS-232), Flying Leads (PPS + GPRMC Synchronization) 33
 - 15.2 MI1(RS-232 + CAN) 33
 - 15.2.1 MI1 Interface, DB9 + Flying Leads Cable..... 33
 - 15.2.2 MI1 Interface, Flying Leads Cable..... 33
 - 15.3 RS-485 Interface, Flying Leads..... 34
 - 15.4 CAN Interface, Flying Leads 34
- 16 Default Configuration 35

HI14 Series Datasheet

Waterproof IMU/VRU/AHRS Module

REV: 1.8

17 Communication Protocols	36
17.1 Serial Binary Protocol	36
17.2 Modbus	36
17.3 CAN	36
18 Disclaimer	37

4 Product Selection

Table 2: Selection Information

Coding format: HI14-a-b-c-d-e						
Identifier	Series	a–Sensor	b–Interface	c–Synchronization	d–Connector	e–Other Information
HI	14	M0: IMU/VRU	USB(RS-232): USB-to-UART (RS-232)	0: No 1: Yes	0: M12 1: PG cable	0: Default Others: Custom
		R2: IMU/VRU	USB(TTL): USB-to-UART (TTL)			
		R3: IMU/VRU/AHRS	URT: UART(TTL)			
		R5: IMU/VRU/AHRS	232: UART(RS-232)			
		S2: IMU/VRU	485: RS-485			
		S3: IMU/VRU/AHRS	CAN: CAN 2.0			
		S5: IMU/VRU/AHRS	422: RS-422 MI1: RS-232 + CAN			

Note 1: For current standard models, refer to the “Ordering Information” section. Other configurations are available as custom options.

Note 2: The synchronization functions supported by the HI14 series include pulse trigger and PPS + GPRMC.

Note 3: In the following sections, HI14XX refers to all products in the HI14 series. HI14RX refers to HI14R2, HI14R3, and HI14R5, while HI14SX refers to HI14S2, HI14S3, and HI14S5.

Note 4: Taking HI14S3-URT-100 as an example, the first digit “1” indicates synchronization support, the second digit “0” indicates an M12 connector, and the third digit “0” indicates the default configuration.

Table 3: HI14 Series Module Configuration

Model	3-Axis Accelerometer	3-Axis Gyroscope	3-Axis Magnetometer
HI14M0	√	√	×
HI14R2	√	√	×
HI14R3	√	√	√
HI14R5	√	√	√
HI14S2	√	√	×
HI14S3	√	√	√
HI14S5	√	√	√

5 Ordering Information

5.1 HI14 M12 Connector Ordering Codes

Table 4: HI14 M12 Connector Ordering Codes

Interface	Model	Name	Description
UART(TTL)	HI14M0-URT-000	IMU/VRU Module	Standard, TTL
	HI14R2-URT-000	IMU/VRU Module	High-performance, TTL
	HI14R2-URT-100	IMU/VRU Module	High-performance, Synchronization, TTL
	HI14R3-URT-000	IMU/VRU/AHRS Module	High-performance, Magnetometer, TTL
	HI14R3-URT-100	IMU/VRU/AHRS Module	High-performance, Synchronization, Magnetometer, TTL
	HI14R5-URT-000	IMU/VRU/AHRS Module	High-performance, Magnetometer, TTL
	HI14R5-URT-100	IMU/VRU/AHRS Module	High-performance, Synchronization, Magnetometer, TTL
	HI14S2-URT-000	IMU/VRU Module	High-performance, Low-noise, TTL
	HI14S2-URT-100	IMU/VRU Module	High-performance, Low-noise, Synchronization, TTL
	HI14S3-URT-000	IMU/VRU/AHRS Module	High-performance, Low-noise, Magnetometer, TTL
	HI14S3-URT-100	IMU/VRU/AHRS Module	High-performance, Low-noise, Synchronization, Magnetometer, TTL
	HI14S5-URT-000	IMU/VRU/AHRS Module	High-performance, Low-noise, Magnetometer, TTL
HI14S5-URT-100	IMU/VRU/AHRS Module	High-performance, Low-noise, Synchronization, Magnetometer, TTL	
UART(RS-232)	HI14M0-232-000	IMU/VRU Module	Standard, RS-232
	HI14R2-232-000	IMU/VRU Module	High-performance, RS-232
	HI14R2-232-100	IMU/VRU Module	High-performance, Synchronization, RS-232
	HI14R3-232-000	IMU/VRU/AHRS Module	High-performance, Magnetometer, RS-232
	HI14R3-232-100	IMU/VRU/AHRS Module	High-performance, Synchronization, Magnetometer, RS-232
	HI14R5-232-000	IMU/VRU/AHRS Module	High-performance, Magnetometer, RS-232
	HI14R5-232-100	IMU/VRU/AHRS Module	High-performance, Synchronization, Magnetometer, RS-232
	HI14S2-232-000	IMU/VRU Module	High-performance, Low-noise, RS-232
	HI14S2-232-100	IMU/VRU Module	High-performance, Low-noise, Synchronization, RS-232
	HI14S3-232-000	IMU/VRU/AHRS Module	High-performance, Low-noise, Magnetometer, RS-232
	HI14S3-232-100	IMU/VRU/AHRS Module	High-performance, Low-noise, Synchronization, Magnetometer, RS-232
	HI14S5-232-000	IMU/VRU/AHRS Module	High-performance, Low-noise, Magnetometer, RS-232
HI14S5-232-100	IMU/VRU/AHRS Module	High-performance, Low-noise, Synchronization, Magnetometer, RS-232	
USB(RS-232)	HI14M0-USB(RS-232)-000	IMU/VRU Module	Standard, USB-to-UART (RS-232)
	HI14R2-USB(RS-232)-000	IMU/VRU Module	High-performance, USB-to-UART (RS-232)
	HI14R3-USB(RS-232)-000	IMU/VRU/AHRS Module	High-performance, Magnetometer, USB-to-UART (RS-232)
	HI14R5-USB(RS-232)-000	IMU/VRU/AHRS Module	High-performance, Magnetometer, USB-to-UART (RS-232)
	HI14S2-USB(RS-232)-000	IMU/VRU Module	High-performance, Low-noise, USB-to-UART (RS-232)
	HI14S3-USB(RS-232)-000	IMU/VRU/AHRS Module	High-performance, Low-noise, Magnetometer, USB-to-UART (RS-232)
	HI14S5-USB(RS-232)-000	IMU/VRU/AHRS Module	High-performance, Low-noise, Magnetometer, USB-to-UART (RS-232)
USB(TTL)	HI14M0-USB(TTL)-000	IMU/VRU Module	Standard, USB-to-UART (TTL)
	HI14R2-USB(TTL)-000	IMU/VRU Module	High-performance, USB-to-UART (TTL)
	HI14R3-USB(TTL)-000	IMU/VRU/AHRS Module	High-performance, Magnetometer, USB-to-UART (TTL)
	HI14R5-USB(TTL)-000	IMU/VRU/AHRS Module	High-performance, Magnetometer, USB-to-UART (TTL)
	HI14S2-USB(TTL)-000	IMU/VRU Module	High-performance, Low-noise, USB-to-UART (TTL)
	HI14S3-USB(TTL)-000	IMU/VRU/AHRS Module	High-performance, Low-noise, Magnetometer, USB-to-UART (TTL)
	HI14S5-USB(TTL)-000	IMU/VRU/AHRS Module	High-performance, Low-noise, Magnetometer, USB-to-UART (TTL)
RS-485	HI14M0-485-000	IMU/VRU Module	Standard, RS-485
	HI14R2-485-000	IMU/VRU Module	High-performance, RS-485
	HI14R3-485-000	IMU/VRU/AHRS Module	High-performance, Magnetometer, RS-485
	HI14R5-485-000	IMU/VRU/AHRS Module	High-performance, Magnetometer, RS-485
	HI14S2-485-000	IMU/VRU Module	High-performance, Low-noise, RS-485
	HI14S3-485-000	IMU/VRU/AHRS Module	High-performance, Low-noise, Magnetometer, RS-485
	HI14S5-485-000	IMU/VRU/AHRS Module	High-performance, Low-noise, Magnetometer, RS-485

RS-422	HI14M0-422-000	IMU/VRU Module	Standard, RS-422
	HI14R2-422-000	IMU/VRU Module	High-performance, RS-422
	HI14R3-422-000	IMU/VRU/AHRS Module	High-performance, Magnetometer, RS-422
	HI14R5-422-000	IMU/VRU/AHRS Module	High-performance, Magnetometer, RS-422
	HI14S2-422-000	IMU/VRU Module	High-performance, Low-noise, RS-422
	HI14S3-422-000	IMU/VRU/AHRS Module	High-performance, Low-noise, Magnetometer, RS-422
CAN 2.0	HI14S5-422-000	IMU/VRU/AHRS Module	High-performance, Low-noise, Magnetometer, RS-422
	HI14M0-CAN-000	IMU/VRU Module	Standard, CAN
	HI14R2-CAN-000	IMU/VRU Module	High-performance, CAN
	HI14R3-CAN-000	IMU/VRU/AHRS Module	High-performance, Magnetometer, CAN
	HI14R5-CAN-000	IMU/VRU/AHRS Module	High-performance, Magnetometer, CAN
	HI14S2-CAN-000	IMU/VRU Module	High-performance, Low-noise, CAN
MI1 (RS-232 + CAN)	HI14S3-CAN-000	IMU/VRU/AHRS Module	High-performance, Low-noise, Magnetometer, CAN
	HI14S5-CAN-000	IMU/VRU/AHRS Module	High-performance, Low-noise, Magnetometer, CAN
	HI14M0-MI1-000	IMU/VRU Module	Standard, MI1(RS-232 + CAN)
	HI14R2-MI1-000	IMU/VRU Module	High-performance, MI1(RS-232 + CAN)
	HI14R3-MI1-000	IMU/VRU/AHRS Module	High-performance, Magnetometer, MI1(RS-232 + CAN)
	HI14R5-MI1-000	IMU/VRU/AHRS Module	High-performance, Magnetometer, MI1(RS-232 + CAN)
	HI14S2-MI1-000	IMU/VRU Module	High-performance, Low-noise, MI1(RS-232 + CAN)
	HI14S3-MI1-000	IMU/VRU/AHRS Module	High-performance, Low-noise, Magnetometer, MI1(RS-232 + CAN)
	HI14S5-MI1-000	IMU/VRU/AHRS Module	High-performance, Low-noise, Magnetometer, MI1(RS-232 + CAN)

5.2 HI14 PG Ordering Codes

Table 5: HI14 PG Ordering Codes

Interface	Model	Name	Description
UART(TTL)	HI14M0-URT-010	IMU/VRU Module	Standard, TTL
	HI14R2-URT-010	IMU/VRU Module	High-performance, UART(TTL)
	HI14R3-URT-010	IMU/VRU/AHRS Module	High-performance, Magnetometer, UART(TTL)
	HI14R5-URT-010	IMU/VRU/AHRS Module	High-performance, Magnetometer, UART(TTL)
	HI14S2-URT-010	IMU/VRU Module	High-performance, Low-noise, UART(TTL)
	HI14S3-URT-010	IMU/VRU/AHRS Module	High-performance, Low-noise, Magnetometer, UART(TTL)
	HI14S5-URT-010	IMU/VRU/AHRS Module	High-performance, Low-noise, Magnetometer, UART(TTL)
UART(RS-232)	HI14M0-232-010	IMU/VRU Module	Standard, UART(RS-232)
	HI14R2-232-010	IMU/VRU Module	High-performance, UART(RS-232)
	HI14R3-232-010	IMU/VRU/AHRS Module	High-performance, Magnetometer, UART(RS-232)
	HI14R5-232-010	IMU/VRU/AHRS Module	High-performance, Magnetometer, UART(RS-232)
	HI14S2-232-010	IMU/VRU Module	High-performance, Low-noise, UART(RS-232)
	HI14S3-232-010	IMU/VRU/AHRS Module	High-performance, Low-noise, Magnetometer, UART(RS-232)
	HI14S5-232-010	IMU/VRU/AHRS Module	High-performance, Low-noise, Magnetometer, UART(RS-232)
RS-485	HI14M0-485-010	IMU/VRU Module	Standard, RS-485
	HI14R2-485-010	IMU/VRU Module	High-performance, RS-485
	HI14R3-485-010	IMU/VRU/AHRS Module	High-performance, Magnetometer, RS-485
	HI14R5-485-010	IMU/VRU/AHRS Module	High-performance, Magnetometer, RS-485
	HI14S2-485-010	IMU/VRU Module	High-performance, Low-noise, RS-485
	HI14S3-485-010	IMU/VRU/AHRS Module	High-performance, Low-noise, Magnetometer, RS-485
	HI14S5-485-010	IMU/VRU/AHRS Module	High-performance, Low-noise, Magnetometer, RS-485
CAN 2.0	HI14M0-CAN-010	IMU/VRU Module	Standard, CAN
	HI14R2-CAN-010	IMU/VRU Module	High-performance, CAN
	HI14R3-CAN-010	IMU/VRU/AHRS Module	High-performance, Magnetometer, CAN
	HI14R5-CAN-010	IMU/VRU/AHRS Module	High-performance, Magnetometer, CAN
	HI14S2-CAN-010	IMU/VRU Module	High-performance, Low-noise, CAN
	HI14S3-CAN-010	IMU/VRU/AHRS Module	High-performance, Low-noise, Magnetometer, CAN
	HI14S5-CAN-010	IMU/VRU/AHRS Module	High-performance, Low-noise, Magnetometer, CAN

5.3 Contact Information

- Email: sales@hipnuc.com
- Website: www.hipnuc.com

6 Document Information

6.1 Revision History

Table 6: Revision History

Version	Date	Author	Change Description
1.0	June 27, 2024	Hipnuc	Initial release
1.1	August 21, 2024	Hipnuc	Updated the minimum input voltage for the RS-232 interface
1.2	August 21, 2024	Hipnuc	Added USB interfaces, updated ordering information, and changed the default bundled cable harness
1.3	August 27, 2024	Hipnuc	Updated attitude angle accuracy specifications and the factory default gyroscope bandwidth
1.4	December 7, 2024	Hipnuc	Added the CAN + RS-232 interface and wiring description, and removed the label description and synchronization section
1.5	March 17, 2025	Hipnuc	Updated Allan variance
1.6	July 10, 2025	Hipnuc	Added HI14S series products
1.7	November 19, 2025	Hipnuc	Corrected certain parameter units
1.8	March 25, 2026	Hipnuc	Reformatted the document and corrected parameters

6.2 Related Documents

1. Command and Programming Manual
2. STEP module
3. RoHS and other compliance documents
4. GUI software and reference examples

7 HI14 System Architecture

The HI14 series supports different output capabilities depending on the model, including IMU, VRU, and AHRS. It also supports multiple operating modes, such as 6-DoF mode, AHRS mode, and humanoid mode.

Depending on the model configuration, the HI14 module may integrate a 3-axis accelerometer, a 3-axis gyroscope, a 3-axis magnetometer, and a high-performance processor. The processor is mainly used for sensor synchronization, calibration, algorithm fusion, and user configuration. The humanoid mode is specifically optimized for the attitude characteristics of bipedal / humanoid robots. For details, refer to the Command and Programming Manual.

7.1 IMU

The HI14 can be used as an inertial measurement unit (IMU), providing users with three-dimensional acceleration and three-dimensional angular rate data that have undergone system-level calibration and compensation. These data are acquired by the internally integrated high-precision accelerometer and gyroscope and can reflect the motion state and dynamic changes of an object in three-dimensional space in real time. Compared with raw inertial devices that have not undergone module-level compensation and calibration, the HI14 offers the advantage of factory-completed system-level calibration and compensation, which significantly improves output consistency and stability and enhances measurement accuracy. These calibrations include cross-axis compensation, scale factor calibration, bias calibration, and temperature compensation.

7.2 VRU

Through its fusion algorithm, the HI14 can output attitude information referenced to gravity, mainly including pitch and roll. In 6-DoF mode, it can also output an estimated yaw value; however, this value does not provide long-term absolute heading reference capability and will accumulate drift over time.

7.3 AHRS

Building on the IMU and VRU functions, the HI14 is further upgraded into a more capable attitude and heading reference system (AHRS) by incorporating a high-precision, wide-range TMR (tunneling magnetoresistance) geomagnetic sensor. By introducing magnetic reference information, the module can output a heading angle with better long-term stability and provide more complete attitude information, including long-term stable pitch, roll, and yaw referenced to magnetic north. It should be noted that AHRS heading accuracy depends on the quality of the magnetic environment; when installed near motors, permanent magnets, ferromagnetic materials, or high-current cable harnesses, magnetic calibration is required and verification under actual operating conditions is recommended.

8 Interface and Pin Definitions

The HI14 connector is a standard M12 circular connector, with a male connector on the sensor side. In the following sections, SGND refers to the signal reference ground and is internally connected to GND. CAN GND / 485 GND refer to the shield/chassis reference ground and are connected to the enclosure. They are not intended for use as logic ground or power ground. Before wiring, determine whether to connect this reference ground according to the grounding scheme of the system.

8.1 M12 5-Pin Definitions



Figure 3: HI14 M12 5-Pin A-Coded Male Connector Pin Numbering

8.1.1 M12 5-Pin UART (TTL) Pin Definitions

Table 7: 5-Pin UART (TTL) Pin Definitions

No.	Color	Name	Type	Description	Remarks
1	Brown	SGND	Power	Signal GND	
2	White	Vs	Power	Power +	
3	Blue	GND	Power	Power ground	
4	Black	RXD1	I	UART1 receive (TTL)	
5	Gray	TXD1	O	UART1 transmit (TTL)	

Note 1: SGND is internally connected to GND.

8.1.2 M12 5-Pin UART (RS-232) Pin Definitions

Table 8: 5-Pin UART (RS-232) Pin Definitions

No.	Color	Name	Type	Description	Remarks
1	Brown	SGND	Power	Signal GND	
2	White	Vs	Power	Power +	
3	Blue	GND	Power	Power ground	
4	Black	RXD1	I	UART1 receive (RS-232)	
5	Gray	TXD1	O	UART1 transmit (RS-232)	

Note 1: SGND is internally connected to GND.

8.1.3 M12 5-Pin RS-485 Pin Definitions

Table 9: 5-Pin RS-485 Pin Definitions

No.	Color	Name	Type	Description	Remarks
1	Brown	485 GND	Power	RS-485, shield/reference ground, connected to the enclosure; may be left floating if unused	
2	White	Vs	Power	Power +	
3	Blue	GND	Power	Power ground	
4	Black	485 A	AIO	RS-485 A	
5	Gray	485 B	AIO	RS-485 B	

Note 1: 485 GND is the shield/chassis reference ground and is connected to the sensor enclosure. It may be left floating if unused. It must not be directly connected to power ground or signal ground.

8.1.4 M12 5-Pin CAN Pin Definitions

Table 10: 5-Pin CAN Pin Definitions

No.	Color	Name	Type	Description	Remarks
1	Brown	CAN GND	Power	CAN shield/reference ground, connected to the enclosure; may be left floating if unused	
2	White	Vs	Power	Power +	
3	Blue	GND	Power	Power ground	
4	Black	CAN H	AIO	CAN High	
5	Gray	CAN L	AIO	CAN Low	

Note 1: CAN GND is the shield/chassis reference ground and is connected to the sensor enclosure. It may be left floating if unused. It must not be directly connected to power ground or signal ground.

8.2 M12 8-Pin Definitions



Figure 4: HI14 M12 A-Coded Male Connector Pin Numbering

8.2.1 M12 8-Pin UART (TTL) Pin Definitions

Table 11: 8-Pin UART (TTL) Pin Definitions

No.	Color	Name	Type	Description	Remarks
1	White	SGND	Power	Signal GND	
2	Brown	Vs	Power	Power +	
3	Green	GND	Power	Power ground	
4	Yellow	RXD1	I	UART1 receive (TTL)	
5	Gray	TXD1	O	UART1 transmit (TTL)	
6	Pink	SGND	Power	Signal GND	
7	Blue	RXD2	I	UART2 receive (TTL), can receive GPRMC messages	
8	Red	I/O	I/O	Multi-function I/O, default synchronization input mode, can be connected to a PPS signal	

Note 1: For other functions of the I/O pin, refer to the Command and Programming Manual.

Note 2: SGND is internally connected to GND.

8.2.2 M12 8-Pin UART (RS-232) Pin Definitions

Table 12: 8-Pin UART (RS-232) Pin Definitions

No.	Color	Name	Type	Description	Remarks
1	White	SGND	Power	Signal GND	
2	Brown	Vs	Power	Power +	
3	Green	GND	Power	Power ground	
4	Yellow	RXD1	I	UART1 receive (RS-232)	
5	Gray	TXD1	O	UART1 transmit (RS-232)	
6	Pink	SGND	Power	Signal GND	
7	Blue	RXD2	I	UART2 receive (RS-232 level), can receive GPRMC messages	
8	Red	I/O	I/O	Multi-function I/O, default synchronization input mode, can be connected to a PPS signal	

Note 1: For other functions of the I/O pin, refer to the Command and Programming Manual.

Note 2: SGND is internally connected to GND.

8.2.3 M12 8-Pin MI1 (RS-232 + CAN) Pin Definitions

Table 13: 8-Pin MI1 (RS-232 + CAN) Pin Definitions

No.	Color	Name	Type	Description	Remarks
1	White	SGND	Power	Signal GND	
2	Brown	Vs	Power	Power +	
3	Green	GND	Power	Power ground	
4	Yellow	RXD1	I	UART1 receive (RS-232)	
5	Gray	TXD1	O	UART1 transmit (RS-232)	
6	Pink	CAN GND	Power	CAN shield/reference ground, connected to the enclosure; may be left floating if unused	
7	Blue	CAN H	AIO	CAN High	
8	Red	CAN L	AIO	CAN Low	

Note 1: CAN GND is the shield/chassis reference ground and is connected to the sensor enclosure. It may be left floating if unused. It must not be directly connected to power ground or signal ground.

8.2.4 M12 8-Pin RS-422 Pin Definitions

Table 14: 8-Pin RS-422 Pin Definitions

No.	Color	Name	Type	Description	Remarks
1	White	SGND	Power	Signal GND	
2	Brown	Vs	Power	Power +	
3	Green	GND	Power	Power ground	
4	Yellow	RX+	AIO	Differential receive +	
5	Gray	RX-	AIO	Differential receive -	
6	Pink	TX+	AIO	Differential transmit +	
7	Blue	TX-	AIO	Differential transmit -	
8	Red	I/O	I/O	Multi-function I/O, default synchronization input mode	

Note 1: For other functions of the I/O pin, refer to the Command and Programming Manual.

8.3 PG Pin Definitions

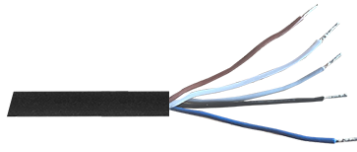

Figure 5: PG Cable

Table 15: PG Pin Definitions

No.	Color	UART (TTL/RS-232)	RS-485	CAN
1	Brown	SGND	485 GND Shield Ground	CAN GND Shield Ground
2	White	Vs	Vs	Vs
3	Blue	GND	GND	GND
4	Black	RXD1	RS-485 A	CAN H
5	Gray	TXD1	RS-485 B	CAN L

9 Specifications

In this section, HI14RX refers to HI14R2, HI14R3, and HI14R5; HI14SX refers to HI14S2, HI14S3, and HI14S5. These designations are used only for parameter classification.

9.1 Gyroscope

Table 16: Gyroscope Specifications

Parameter	Product	Conditions	Min	Type	Max	Unit	Remarks
Range	HI14M0/HI14RX			±250			
				±500		°/s	Default: ±2000
				±1000			
				±2000			
Range	HI14SX			±250			
				±500		°/s	Default: ±2000
				±1000			
				±2000			
Digital Resolution	HI14M0/HI14RX			16	16	bit	
	HI14SX			16	20		
Scale Factor Error	HI14M0	Rotation at 100 °/s		<600	850	ppm	Type: RMS
	HI14R2/HI14R3	Rotation at 100 °/s		<600	850		
	HI14R5	Rotation at 100 °/s		<400	600		
	HI14S2/HI14S3	Rotation at 100 °/s		<600	1200		
	HI14S5	Rotation at 100 °/s		<400	600		
Nonlinearity				±0.05		%FS	1
Noise Density	HI14M0	Bandwidth 47 Hz		0.014		°/s/√Hz	
	HI14R2/HI14R3	Bandwidth 47 Hz		0.008			
	HI14R5	Bandwidth 47 Hz		0.005			
	HI14S2/HI14S3	Bandwidth 10 Hz		0.0025			
	HI14S5	Bandwidth 10 Hz		0.0015			
3 dB Bandwidth	HI14M0/HI14RX			80	200	Hz	2
	HI14SX			80	400		
Zero-rate output				±0.1	±0.2	°/s	3, RMS
Sampling Rate				1000		Hz	
Bias Instability Allan variance	HI14M0	X		2.5	4	°/h	Type: 1σ Max: 3σ
		Y		3.2	5.5		
		Z		3	5.5		
	HI14R2/HI14R3	X		1.5	2.5		
		Y		1.9	3.2		
		Z		1.7	3.2		
	HI14R5	X		1.1	1.5		
		Y		1.4	2		
		Z		1.2	2		

HI14 Series Datasheet

Waterproof IMU/VRU/AHRS Module

REV: 1.8

Bias Instability		X	4	6	°/h	Type: 1σ Max: 3σ
	HI14S2/HI14S3	Y	1.5	2.5		
		Z	1.7	4		
Allan variance		X	0.9	1.5	°/h	Type: 1σ Max: 3σ
	HI14S5	Y	1.1	1.4		
		Z	1.0	1.5		
Bias Stability 10 s averaging	HI14M0	X	10	14	°/h	Type: 1σ Max: 3σ
		Y	13	17		
		Z	10	13		
	HI14R2/HI14R3	X	5.5	7		
		Y	7.5	9		
		Z	5.5	7		
	HI14R5	X	3.9	5		
		Y	5.3	6.5		
		Z	3.9	5		
	HI14S2/HI14S3	X	10	16		
		Y	4	7		
		Z	5	13		
HI14S5	X	3.1	5			
	Y	2.9	4.5			
	Z	3.0	6.5			
Bias Repeatability	HI14M0	X	20	36	°/h	Type: 1σ Max: 3σ
		Y	36	61		
		Z	16	25		
	HI14R2/HI14R3	X	11.5	21		
		Y	15	30		
		Z	9.5	15		
	HI14R5	X	8	15		
		Y	11	18		
		Z	7	11		
	HI14S2/HI14S3	X	11	35		
		Y	10	30		
		Z	9	20		
HI14S5	X	7	18			
	Y	6	19			
	Z	6	13			
Angle Random Walk	HI14M0	X	0.55	1.1	°/√h	Type: 1σ Max: 3σ
		Y	0.82	1.2		
		Z	0.47	0.7		
Allan variance	HI14R2/HI14R3	X	0.3	0.6		
		Y	0.4	0.7		
		Z	0.2	0.4		

Angle Random Walk Allan variance	HI14R5	X	0.22	0.45	°/√h	Type: 1σ Max: 3σ
		Y	0.25	0.5		
		Z	0.15	0.3		
	HI14S2/HI14S3	X	0.12	0.16		
		Y	0.1	0.12		
		Z	0.1	0.14		
	HI14S5	X	0.055	0.07		
		Y	0.057	0.07		
		Z	0.059	0.07		
Bias Drift over Temperature	-40 °C to 85 °C		0.07	0.15	°/s	4
g-Sensitivity	XYZ		0.05	°/s/g		

- Note 1:** Maximum deviation from the best-fit straight line within the specified range.
- Note 2:** Different modes have different bandwidths. The default 6-DoF mode is 80 Hz.
- Note 3:** After initial bias calibration, the bias can be estimated in real time by the algorithm engine.
- Note 4:** Measured using a thermal chamber and rate table in the Hipnuc laboratory, with a temperature ramp rate of less than 3 °C/min.

HI14 Series Datasheet

Waterproof IMU/VRU/AHRS Module

REV: 1.8

9.2 Accelerometer

Table 17: Accelerometer Specifications

Parameter	Product	Conditions	Min	Type	Max	Unit	Remarks	
Range	HI14M0/HI14RX			±3		g	Default: ±12	
				±6				
				±12				
				±24				
	HI14SX			±2		g	Default: ±16	
				±8				
			±16					
			±32					
Digital Resolution	HI14M0/HI14RX		16		16	bit		
	HI14SX		16		20			
Initial Bias			1		2	mg	Type: RMS	
Nonlinearity			±0.01			%FS	1	
Noise Density	HI14M0		0.16		0.2	mg/√Hz		
	HI14R2/HI14R3		0.1		0.12			
	HI14R5		0.072		0.085			
	HI14S2/HI14S3	Bandwidth 10 Hz	0.05		0.07			
	HI14S5	Bandwidth 10 Hz	0.03		0.045			
3 dB Bandwidth	HI14M0/HI14RX		90		200	Hz	2	
	HI14SX		90		400			
Sampling Rate			1000			Hz		
Bias Instability Allan variance	HI14M0	X		0.021		0.035	mg	Type: 1σ Max: 3σ
		Y		0.032		0.065		
		Z		0.023		0.03		
	HI14R2/HI14R3	X		0.015		0.02		
		Y		0.02		0.045		
		Z		0.015		0.02		
	HI14R5	X		0.01		0.014		
		Y		0.014		0.016		
		Z		0.011		0.015		
	HI14S2/HI14S3	X		0.012		0.02		
		Y		0.009		0.015		
		Z		0.016		0.022		
	HI14S5	X		0.0045		0.006		
		Y		0.0065		0.009		
		Z		0.01		0.014		
Bias Stability 10 s averaging	HI14M0	X		0.068		0.1	mg	Type: 1σ Max: 3σ
		Y		0.09		0.19		
		Z		0.07		0.1		

Bias Stability 10 s averaging	HI14R2/HI14R3	X	0.06	0.1	mg	Type: 1σ Max: 3σ
		Y	0.055	0.15		
		Z	0.05	0.06		
	HI14R5	X	0.04	0.07		
		Y	0.04	0.11		
		Z	0.035	0.045		
	HI14S2/HI14S3	X	0.032	0.055		
		Y	0.022	0.032		
		Z	0.048	0.082		
	HI14S5	X	0.011	0.015		
		Y	0.018	0.023		
		Z	0.03	0.05		
Bias Repeatability	HI14M0	X	0.22	0.4	mg	Type: 1σ Max: 3σ
		Y	0.15	0.21		
		Z	0.12	0.2		
	HI14R2/HI14R3	X	0.127	0.25		
		Y	0.09	0.15		
		Z	0.07	0.15		
	HI14R5	X	0.08	0.15		
		Y	0.06	0.1		
		Z	0.05	0.09		
	HI14S2/HI14S3	X	0.1	0.3		
		Y	0.06	0.2		
		Z	0.1	0.2		
HI14S5	X	0.06	0.18			
	Y	0.04	0.125			
	Z	0.06	0.125			
Velocity Random Walk Allan Variance	HI14M0	XYZ	0.09	0.11	m/s/√h	Type: 1σ Max: 3σ
	HI14R2/HI14R3	XYZ	0.055	0.065		
	HI14R5	XYZ	0.04	0.046		
	HI14S2/HI14S3	XYZ	0.019	0.03		
	HI14S5	XYZ	0.01	0.012		
Bias Variation over Temperature (-40 °C to 85 °C)	HI14M0/HI14RX	XYZ	2	5	mg	3
	HI14S2/HI14S3	XY	2	5		
		Z	6	15		
	HI14S5	XY	2	5		
		Z	5	10		

Note 1: Maximum deviation from the best-fit straight line within the specified range
Note 2: Different modes have different bandwidths. The default 6-DoF mode is 90 Hz.
Note 3: Measured using a thermal chamber and rate table in the Hipnuc laboratory, with a temperature ramp rate of less than 3 °C/min.

9.3 Magnetometer

Table 18: Magnetometer Specifications

Parameter	Conditions	Min	Type	Max	Unit	Remarks
Range			±2000		μT	
Noise		0.19	0.45		μT	
Nonlinearity		±10	±20		μT	

9.4 Temperature Sensor Specifications

Table 19: Temperature Sensor Specifications

Parameter	Conditions	Min	Type	Max	Unit	Remarks
Range		-40	-	85	°C	
Offset Error			±5		°C	

9.5 Fusion Accuracy

Unless otherwise specified, the following attitude accuracy values are measured after factory calibration under typical installation conditions. Actual performance depends on installation conditions and calibration status, especially magnetic calibration where applicable.

Table 20: Attitude Accuracy

Parameter	Product	Conditions	Min	Type	Max	Unit	Remarks
Pitch/Roll (Static)				0.15	0.2	°	1
Pitch/Roll (Dynamic)				0.2	0.3	°	
Heading Accuracy (AHRS)				2	3	°	2
Static Heading Drift (6-DoF)		Static for 2 h		0.15	0.2	°	
Dynamic Heading Drift (6-DoF)	HI14M0			±10	±18	°	3
	HI14RX/HI14SX			±5	±10	°	
Heading Rotation Error (6-DoF)	HI14M0/HI14R2/HI14R3	100 °/s rotation		0.2	0.3	°	4
	HI14S2/HI14S3			0.2	0.4	°	
	HI14R5/HI14S5			0.15	0.2	°	

Note 1: The data are referenced to the horizontal plane and are based on tests conducted on 20 samples.

Note 2: Measured after geomagnetic calibration in a magnetically undisturbed environment. The product must be configured in AHRS mode.

Note 3: Measured over 1 hour of operation on an indoor cleaning robot platform; results are given as 1σ. In 6-DoF mode, heading is an estimated value without magnetic reference. Its long-term stability is affected by initial alignment, motion conditions, environmental conditions, and time.

Note 4: Average error per revolution when the module rotates 10 cycles on a turntable.

9.6 Typical Usage Limits

- In 6-DoF mode, the heading angle drifts over time and is not suitable for long-term absolute heading holding.
- AHRS mode depends on the magnetic environment. Proximity to motors, permanent magnets, or high-current cable harnesses can affect heading accuracy.
- Attitude accuracy is affected by mounting flatness, mechanical stress, vibration, and linear acceleration.
- For high-dynamic applications, validation is recommended after installation in the complete system.

10 System and Electrical Parameters

10.1 Electrical Parameters

Table 21: Electrical Parameters

Parameter	Conditions	Min	Type	Max	Unit	Remarks
Operating voltage range Vs	UART (TTL / RS-232)/RS-422	4.8	-	48	V	
	RS-485/CAN	6	-	48		
Power consumption (24 V supply)	HI14M0			300	mW	
	HI14R2/HI14R3/HI14S2/HI14S3			400		
	HI14R5/HI14S5			600		
V _{OL}			-	0.4	V	
V _{OH}		2.6			V	
V _{IL}		-0.3		1	V	
V _{IH}		1.9		3.6	V	

Note 1: The UART (TTL) / I/O signal levels are independent of the supply voltage and must not be directly connected to logic levels above 5 V.

10.2 Interface Parameters

Table 22: Interface Parameters

Interface	Conditions	Parameter	Min	Type	Max	Unit	Remarks
UART1		Baud rate	9600	115200	921600	bps	
		Output Data Rate	0	100	1000	Hz	
UART2		Baud rate		115200		bps	Receives GPRMC messages
		Baud rate	125	500	1000	kbps	
CAN		Output Data Rate	0	100	200	Hz	
		Terminal resistor		Not built-in			No terminal resistor integrated inside the module
RS-485	Modbus	Baud rate	9600	115200	115200	bps	Master-slave request-response mode
		Output Data Rate		Passive output			
	Non-Modbus	Baud rate	9600	115200	460800	bps	Active output
		Output Data Rate	0	100	250	Hz	
		Terminal resistor		Not built-in			No terminal resistor integrated inside the module
RS-422		Baud rate	9600	115200	921600	bps	
		Output Data Rate	0	100	1000	Hz	
		Terminal resistor		Not built-in			No terminal resistor integrated inside the module

Note 1: Both the baud rate and output frame rate are configurable. The actual available output data rate depends on the output data content, message length, and communication configuration. For details, refer to the Command and Programming Manual.

10.3 System Parameters

Table 23: System Parameters

Parameter	Conditions	Value	Remarks
Dimensions	M12	59 × 40 × 20 mm (including connector)	
	PG	40 × 36 × 16.5 mm (excluding cable outlet)	
Weight		<75 g	
System startup time		2 s	1
Screw specification		M3	
Operating temperature		-40 °C to 85 °C	
Enclosure material		Aluminum alloy	
Vibration resistance		1.0 mm (10 Hz to 58 Hz), ≤20 g (58 Hz to 600 Hz)	
Environmental compliance		Compliant with relevant RoHS requirements	2
Drop test		Free drop 3 times from a 75 cm-high lab bench	3
Temperature Shock Test		Temperature increased from -40 °C to 85 °C within 1 hour, repeated 5 times	3

Note 1: Time from power-on to valid data output.

Note 2: For other compliance materials, certifications, and conformity documents, refer to the latest official information

Note 3: Factory/design verification test condition; does not represent the recommended long-term operating limit

10.4 Absolute Maximum Ratings

Table 24: Absolute Maximum Ratings

Parameter	Limit	Description
Mechanical shock	2000 g	Duration < 0.2 ms
Storage temperature	-40 °C to 85 °C	
ESD (HBM)	30 kV	JEDEC/ESDA JS-001
Input voltage	50 V	
I/O to GND	3.6 V	
TXD (TTL) to GND	3.6 V	
RXD (TTL) to GND	3.6 V	
TXD (RS-232) to GND	±13.2 V	
RXD (RS-232) to GND	±24 V	
CAN_H, CAN_L to GND	±70 V	
CAN_H to CAN_L	±27 V	
RS-485 A, RS-485 B to GND	-8 to 13 V	
RS-485 A to RS-485 B	21 V	
TX+, TX-, RX+, RX- to GND	±14 V	
TX+, TX-, RX+, RX- common-mode input voltage	-7 to 12 V	

Note 1: Exceeding the absolute maximum ratings may cause permanent damage to the device. Normal operation is not guaranteed under these conditions.

11 Mechanical Dimensions

11.1 HI14 M12 Mechanical Dimensions

All dimensions are in mm.

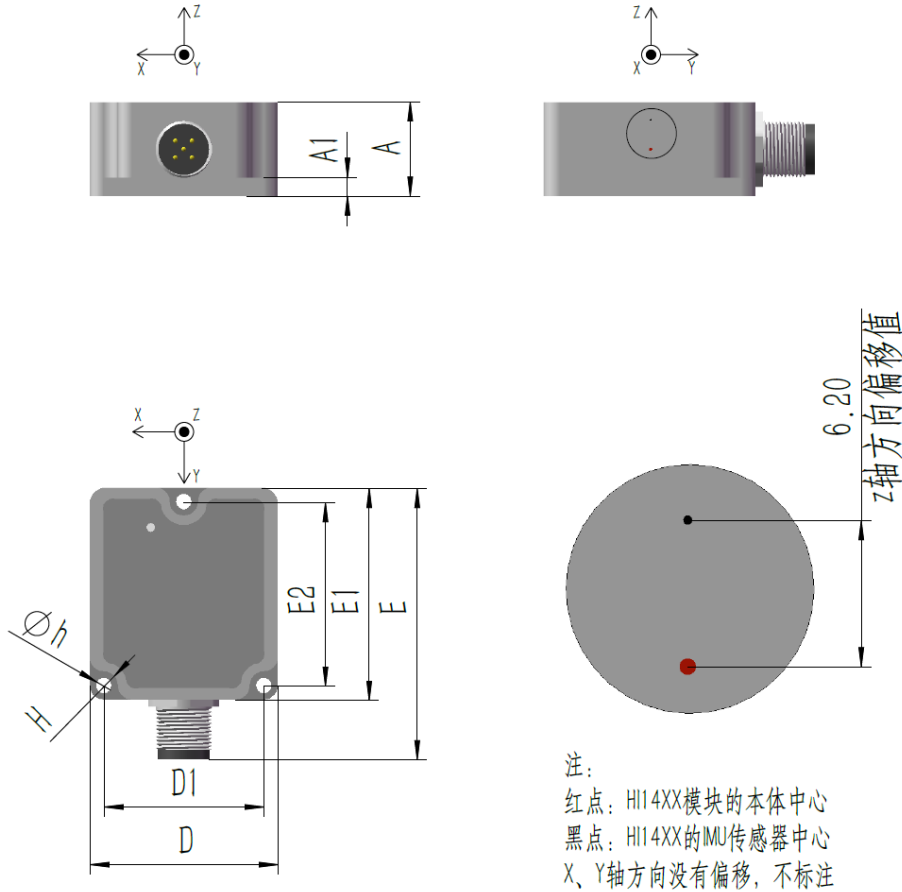

Figure 6: HI14 M12 Mechanical Dimensions

Table 25: HI14 M12 Dimensional Data

Symbol	Min (mm)	Type (mm)	Max (mm)
A	19.8	20	20.2
A1	3.8	4	4.2
D	39.8	40	40.2
D1	33.85	34	34.15
E	58.5	59	59.5
E1	44.8	45	45.2
E2	38.85	39	39.15
H	R2.9	R3	R3.1
h	Φ3.1	Φ3.2	Φ3.3

11.2 HI14 PG Mechanical Dimensions

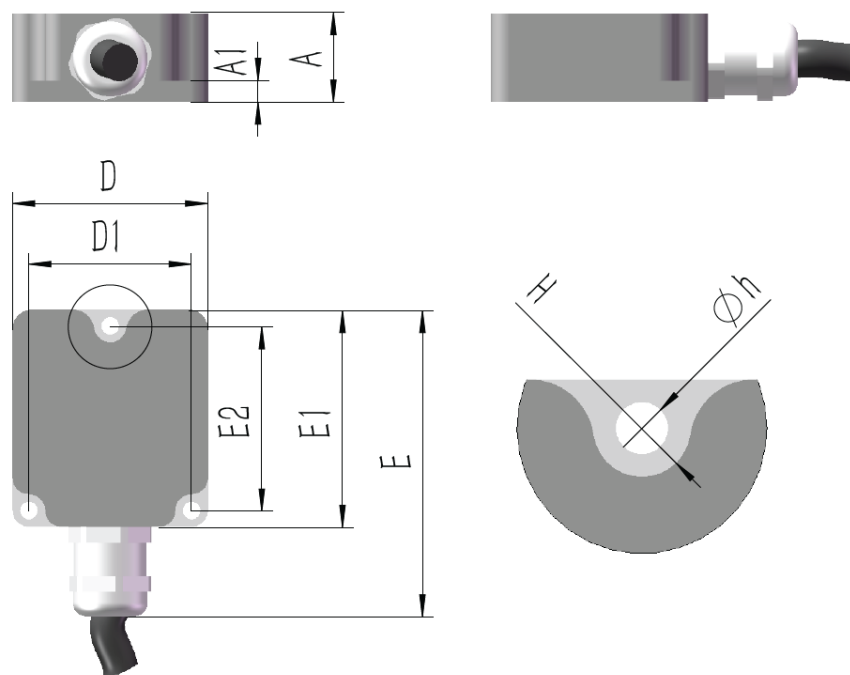

Figure 7: HI14 PG Mechanical Dimensions

Table 26: HI14 PG Dimensional Data

Symbol	Min (mm)	Type (mm)	Max (mm)
A	16.3	16.5	16.7
A1	3.8	4	4.2
D	35.8	36	36.2
D1	29.85	30	30.15
E	53	56	57
E1	39.8	40	40.2
E2	33.85	34	34.15
H	R2.9	R3	R3.1
h	Φ3.1	Φ3.2	Φ3.3

12 Coordinate System

12.1 ENU (Default)

The body frame adopts the Right-Forward-Up (RFU) coordinate system, and the geodetic frame adopts the East-North-Up (ENU) coordinate system. The axes of acceleration and gyroscope are shown in the figure below:

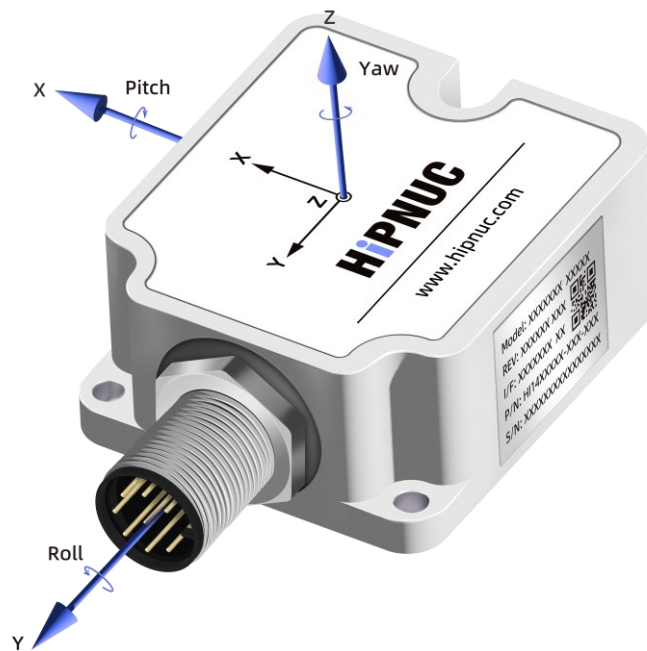

Figure 8: HI14 Coordinate System

The Euler angles are reported in the Z-X-Y (312) rotation sequence. The detailed definition is as follows:

- Rotation around the Z-axis: Heading Angle (Yaw, ψ); Range: $-180^\circ - 180^\circ$
- Rotation around the X-axis: Pitch Angle (θ); Range: $-90^\circ - 90^\circ$
- Rotation around the Y-axis: Roll Angle (ϕ); Range: $-180^\circ - 180^\circ$

When the module coordinate frame coincides with the reference coordinate frame, the ideal Euler angle outputs are Pitch = 0° , Roll = 0° , and Yaw = 0° .

The quaternion order, Euler angle definitions, and coordinate transformation conventions are defined in the Command and Programming Manual and shall prevail.

12.2 NWU and NED

The body frame can also be configured to the North-West-Up (NWU) or North-East-Down (NED) coordinate system. Users need to configure it independently. For details, refer to the Command and Programming Manual.

13 Installation

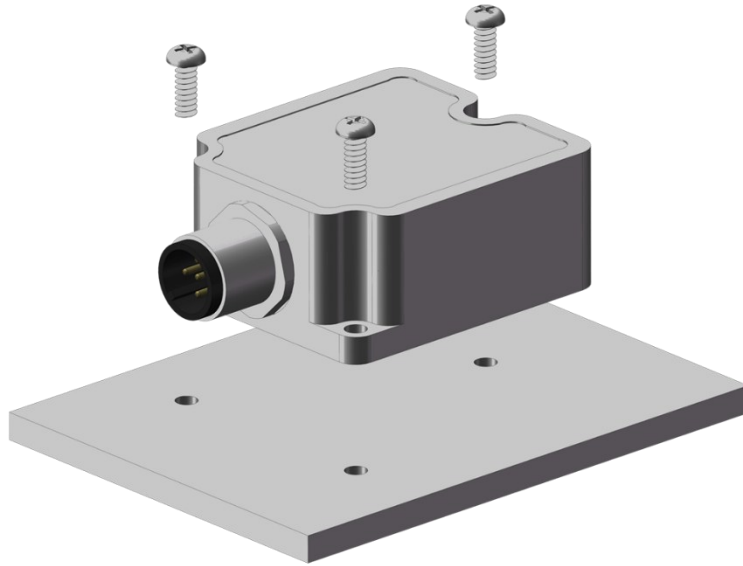

Figure 9: Installation Diagram

The following points shall be observed when installing the HI14:

1. The mounting surface should be as flat as possible and rigidly fixed.
2. Avoid installation near high-temperature heat sources.
3. Avoid continuous stress on the module caused by cable harness pulling.
4. AHRS models should be kept away from motors, speakers, permanent magnets, and high-current cable harnesses. It is recommended to perform magnetic calibration again after installation is completed.
5. For vibration conditions, actual system-level calibration and validation are recommended.

14 Cable

14.1 USB Type-A to M12 A-Coded Female Connector Cable (RS-232)



Figure 10: USB Type-A to M12 A-Coded Female Connector Cable (RS-232)

Note 1: The default cable length is 3.0 m, with a built-in USB-to-UART (RS-232) module.

14.2 USB Type-A to M12 A-Coded Female Connector Cable (TTL)



Figure 11: USB Type-A to M12 A-Coded Cable (TTL)

Note 1: The default cable length is 3.0 m, with a built-in USB-to-UART (TTL) module.

14.3 DB9 Female Connector + Flying Leads to M12 5-Pin A-Coded Female Connector Cable



Figure 12: DB9 Female Connector + Flying Leads to M12 A-Coded 5-Pin Cable

Note 1: The default cable length is 3.0 m.

14.4 DB9 Female Connector + Flying Leads to M12 8-Pin A-Coded Female Connector Cable



Figure 13: DB9 Female Connector + Flying Leads to M12 A-Coded 8-Pin Cable

Note 1: The default cable length is 3.0 m.

14.5 Flying Leads to M12 5-Pin A-Coded Female Connector Cable



Figure 14: Flying Leads to M12 5-Pin A-Coded Female Connector Cable

Note 1: The default cable length is 3.0 m.

14.6 Flying Leads to M12 8-Pin A-Coded Female Connector Cable



Figure 15: Flying Leads to M12 8-Pin A-Coded Female Connector Cable

Note 1: The default cable length is 3.0 m.

14.7 Applicable Products for Cables

Table 27: Applicable Products for Cables

Cable	Product	Remarks
USB Type-A to M12 5-Pin A-Coded Female Connector Cable (RS-232)	HI14XX-USB(RS-232)-000 HI14XX-232-000	Built-in USB-to-UART (RS-232) module
USB Type-A to M12 5-Pin A-Coded Female Connector Cable (TTL)	HI14XX-USB(TTL)-000 HI14XX-URT-000	Built-in USB-to-UART (TTL) module
DB9 Female Connector + Flying Leads to M12 5-Pin A-Coded Female Connector Cable	HI14XX-232-000	
DB9 Female Connector + Flying Leads to M12 8-Pin A-Coded Female Connector Cable	HI14XX-232-100 HI14XX-URT-000	
Flying Leads to M12 5-Pin A-Coded Female Connector Cable	HI14XX-232-000 HI14XX-485-000 HI14XX-CAN-000	
Flying Leads to M12 8-Pin A-Coded Female Connector Cable	HI14XX-URT-100 HI14XX-232-100 HI14XX-MI1-000 HI14XX-422-000	MI1 interface: RS-232 + CAN

14.8 Default Factory-Supplied Cable

Table 28: Default Factory-Supplied Cable

Product	Cable
HI14XX-USB(RS-232)-000	USB Type-A to M12 A-Coded Female Connector Cable (RS-232)
HI14XX-USB(TTL)-000	USB Type-A to M12 A-Coded Female Connector Cable (TTL)
HI14XX-232-000	DB9 Female Connector + Flying Leads to M12 5-Pin A-Coded Female Connector Cable
HI14XX-232-100	DB9 Female Connector + Flying Leads to M12 8-Pin A-Coded Female Connector Cable
HI14XX-URT-000	Flying Leads to M12 5-Pin A-Coded Female Connector Cable
HI14XX-URT-100	Flying Leads to M12 8-Pin A-Coded Female Connector Cable
HI14XX-485-000	Flying Leads to M12 5-Pin A-Coded Female Connector Cable
HI14XX-CAN-000	Flying Leads to M12 5-Pin A-Coded Female Connector Cable
HI14XX-422-000	Flying Leads to M12 8-Pin A-Coded Female Connector Cable
HI14XX-MI1-000	Flying Leads to M12 8-Pin A-Coded Female Connector Cable

Note 1: The default cable length is 3.0 m. Please contact us if other cable types or custom cables are required.

14.9 PG

The PG cable outlet is provided as a 5-wire flying lead by default. For pin definitions and wiring methods, refer to the M12 5-pin definitions.

15 How to Connect

15.1 UART (TTL / RS-232)

15.1.1 UART (TTL / RS-232) to USB

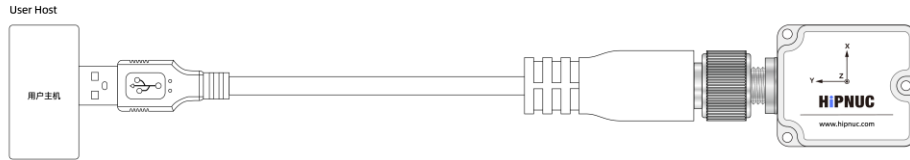

Figure 16: Wiring Diagram for UART (TTL / RS-232) to USB

15.1.2 UART (RS-232), DB9 Connector

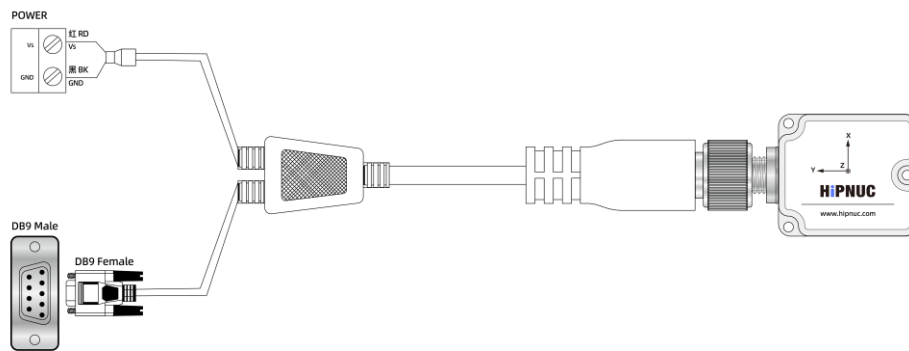

Figure 17: Wiring Diagram for UART (RS-232) with DB9 Connector

15.1.3 UART (RS-232), DB9 Connector (Trigger Synchronization)

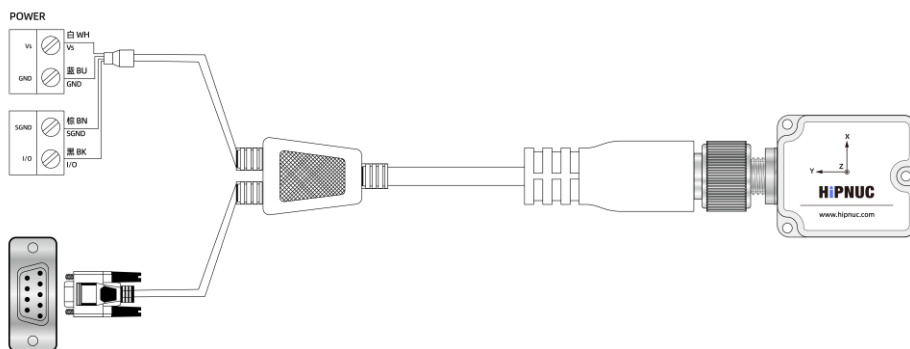

Figure 18: Wiring Diagram for UART (RS-232) Trigger Synchronization with DB9 Connector

Note 1: The I/O of the HI14 is configured as synchronous input mode by default. It can also be configured as synchronous output mode to serve as a Data Ready signal. For details, refer to the Command and Programming Manual.

HI14 Series Datasheet

Waterproof IMU/VRU/AHRS Module

REV: 1.8

15.1.4 UART (RS-232), DB9 Connector (PPS + GPRMC Synchronization)

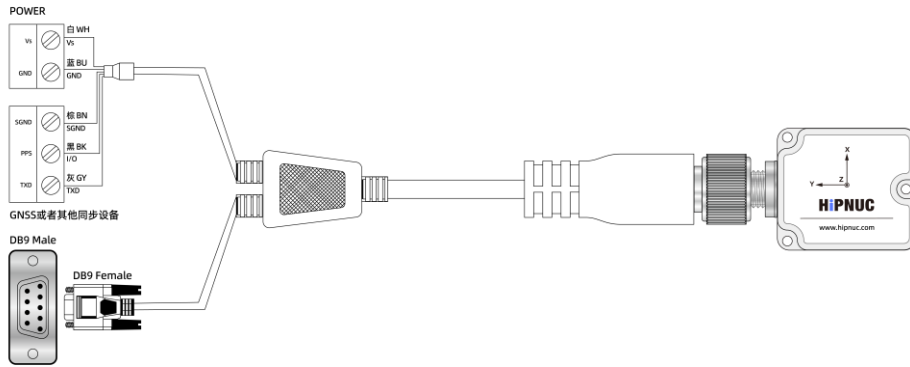

Figure 19: Wiring Diagram for UART (RS-232) PPS + GPRMC Synchronization with DB9 Connector

Note 1: The I/O of the HI14 operates in synchronous input mode in this configuration. The user's synchronization system shall provide PPS and GPRMC information. For details, refer to the Command and Programming Manual.

15.1.5 UART (TTL / RS-232), Flying Leads

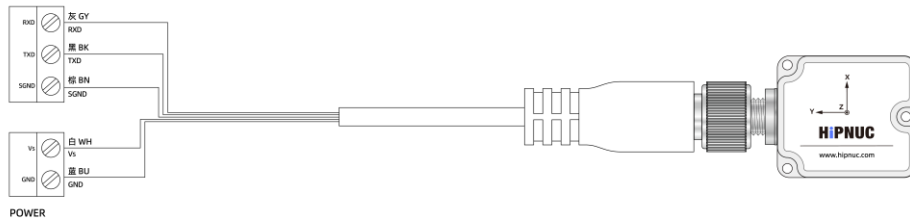

Figure 20: Wiring Diagram for UART (TTL / RS-232) with Flying Leads

Note 1: SGND and GND are internally connected. If the user's power supply system and data receiving system share a common ground, the SGND wiring may be omitted.

15.1.6 UART (TTL / RS-232), Flying Leads (Trigger Synchronization)

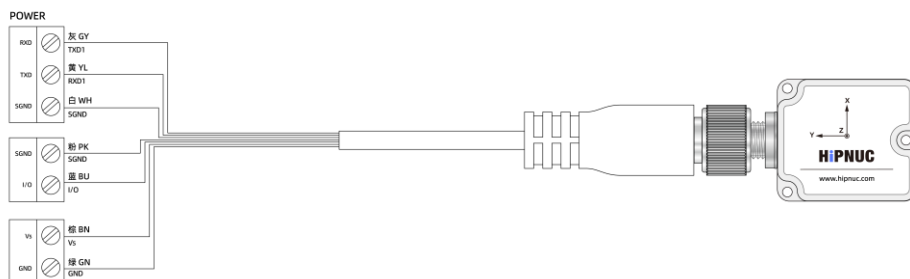

Figure 21: Wiring Diagram for UART (TTL / RS-232) Trigger Synchronization with Flying Leads

Note 1: SGND and GND are internally connected. If the user's synchronization system, power supply system, and data receiving system share a common ground, the SGND wiring may be reduced as appropriate, depending on which systems share the same ground.

15.1.7 UART (TTL / RS-232), Flying Leads (PPS + GPRMC Synchronization)

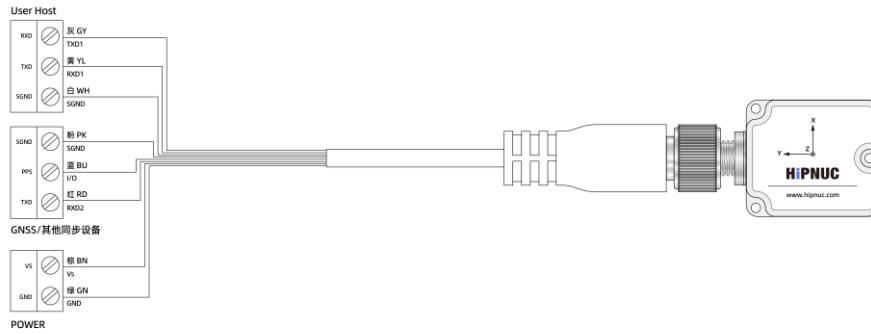

Figure 22: Wiring Diagram for UART (TTL / RS-232) PPS + GPRMC Synchronization with Flying Leads

Note 1: SGND and GND are internally connected. If the user’s synchronization system, power supply system, and data receiving system share a common ground, the SGND wiring may be reduced as appropriate, depending on which systems share the same ground.

15.2 MI1(RS-232 + CAN)

15.2.1 MI1 Interface, DB9 + Flying Leads Cable

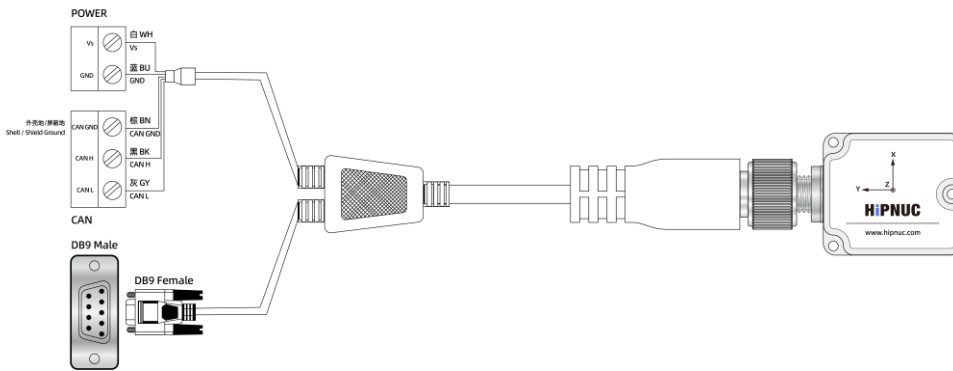

Figure 23: Wiring Diagram for MI1 (RS-232 + CAN) with DB9 Connector + Flying Leads

Note 1: CAN GND here is the CAN shield/chassis reference ground and is connected to the sensor housing. It may be left unconnected if not used. Do not connect it directly to power ground or signal ground.

15.2.2 MI1 Interface, Flying Leads Cable

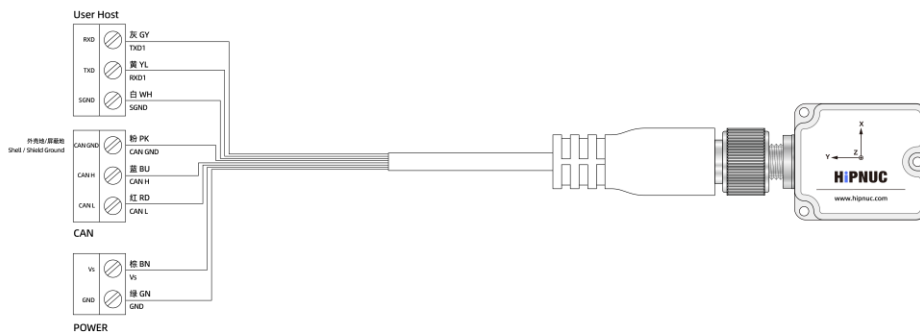

Figure 24: Wiring Diagram for MI1 (RS-232 + CAN) with Flying Leads

HI14 Series Datasheet

Waterproof IMU/VRU/AHRS Module

REV: 1.8

Note 1: CAN GND here is the shield/chassis reference ground and is connected to the sensor housing. It may be left unconnected if not used. Do not connect it directly to power ground or signal ground.

15.3 RS-485 Interface, Flying Leads

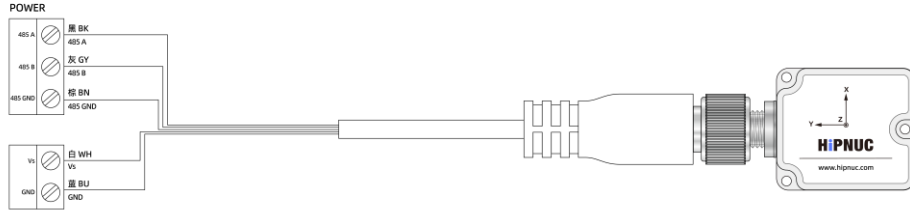

Figure 25: Wiring Diagram for RS-485 with Flying Leads

Note 1: 485 GND here is the shield/chassis reference ground and is connected to the sensor housing. It may be left unconnected if not used. Do not connect it directly to power ground or signal ground.

15.4 CAN Interface, Flying Leads

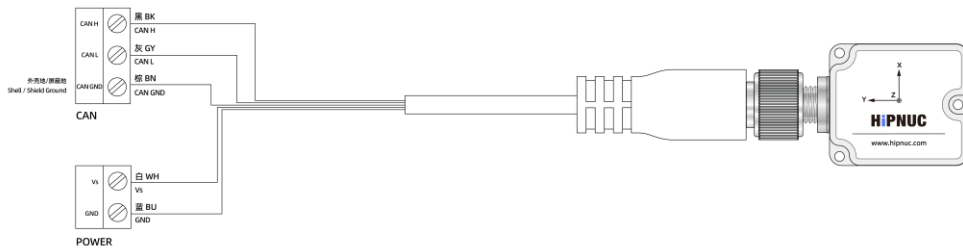

Figure 26: Wiring Diagram for CAN with Flying Leads

Note 1: CAN GND here is the shield/chassis reference ground and is connected to the sensor housing. It may be left unconnected if not used. Do not connect it directly to power ground or signal ground.

16 Default Configuration

Table 29: Default Configuration

Item	Product	Default Value	Remarks
UART		UART1	
Baud Rate		115200	
Frame Format		8N1	
Data Output Rate		100 Hz	
Default Protocol		Custom Binary Serial Protocol	
RS-422 Baud Rate		115200	
Frame Format		8N1	
Data Output Rate		100 Hz	
Default Protocol		Custom Binary Serial Protocol	
RS-485 Baud Rate		115200	
Frame Format		8N1	
Data Output Rate		100 Hz	
Default Protocol		Modbus	
120 Ω Termination Resistor		None	
CAN Baud Rate		500 kbps	
Data Output Rate		100 Hz	
Default Protocol		SAE J1939	1
120 Ω Termination Resistor		None	
Coordinate System		ENU / RFU	
Gyroscope Range		±2000 °/s	
Accelerometer Range	HI14M0/HI14RX	±12 g	
	HI14SX	±16 g	
Mode		6-DoF	
Output Messages		Acceleration	
		Angular Rate	
		Euler Angles	
		Quaternion	
		Temperature	
		Local Timestamp	

Note 1: The current factory-default CAN protocol is SAE J1939, applicable to firmware version 1.7.1 or later. Please contact us if CANopen is required.

17 Communication Protocols

17.1 Serial Binary Protocol

The product supports a serial binary communication protocol. For detailed message formats, output configuration, and command definitions, refer to the Command and Programming Manual.

17.2 Modbus

The RS-485 communication protocol complies with the Modbus RTU specification. For detailed protocol definitions, refer to the Command and Programming Manual.

17.3 CAN

The CAN interface supports CANopen and SAE J1939 communication for data output and interaction. For detailed message definitions, object mapping, or PGN allocation, refer to the Command and Programming Manual.

18 Disclaimer

The parameters listed in this document are typical values, maximum values, or test values under specified test conditions and do not constitute a final delivery commitment. Hipnuc reserves the right to make changes to the products, this document, and related information without prior notice. Final delivery specifications shall be subject to the order, technical agreement, or latest official documentation confirmed by both parties.